

Con-Tech

MANUFACTURING, INC.

REPLACEMENT PARTS

(OEM PARTS FOR CTM MIXERS & "WILL FIT" PARTS FOR MTM MIXERS)

HIGH PERFORMANCE
The Next Generation in High Performance Mixer Technology
The New Standard.



BridgeKing



MADE IN THE
USA

EXTREME DUTY

Ph: (507) 374-2239 Fax: (507) 374-2548
www.ctmmixers.com

Rev 4.30

Categories	Description	Page
Chutes		
	Mains, Foldovers, Extensions, & Transitions.....	4
	Side Mount Chute Accessories	5
	Hanging Chute Accessories.....	6
Hoppers & Collectors		
	Hoppers & Components.....	7
	Collectors & Bibs	8
Pedestals		
	Rear Pedestals.....	9
	Rear Pivot Assembly.....	10-11
	Rollers	12
	HP Ladders & Platforms.....	13
	Ladders & Platforms	14
	Front Pedestals	15
Air Systems		
	Air Control Valves & Accessories.....	16
Hydraulics		
	Gear Boxes.....	17
	Fan Coolers	18
	Hydraulic Cylinders	19
	Hydraulic Pumps & Motors	20-21
	Hydraulic Control Manifolds.....	22-23
Axles		
	BridgeKing Trailer & Components	24-25
Controls		
	In Cab Control Box	26-27
	Rear Control Pendant	28
	Rear Control Box.....	29
	Control Cables & Clevis	30
Reservoirs & Meters		
	Slump Meter & Brackets	31
	Oil Reservoir and Mounting Brackets	32

Categories	Description	Page
Water System		
	Water Tanks.....	33
	Site Gauge Mount Parts	34
	Water Tank Brackets.....	35
Fenders		
	Steel & Aluminum Fenders	36
Bumpers		
	Front Bumpers	37
	Rear Bumpers.....	38
Mixers Components		
	Drum Parts.....	39
Miscellaneous		
	Lights, Wiring, Harnesses, and Accessories.....	40
	General Accessories	41
Washout Systems		
	Chute Washout Systems.....	42
Spec Sheets		
	HP Replacement Drum Order Form	43
	Replacement Drum Order Form.....	44
	Hopper Replacement Order Form	45

Part Number Cross Reference

Credit Application

Note: Con-Tech Manufacturing, Inc. manufactures “original equipment manufacturer” (“OEM”) fabricated metal replacement parts only for its own CTM mixers. The fabricated metal replacement parts referred to with respect to MTM mixers in this Parts Book are “Will Fit” parts for MTM mixers manufactured by Con-Tech Manufacturing, Inc. They are not OEM parts (i.e., parts manufactured and/or supplied by McNeilus Truck and Manufacturing, Inc.) for MTM mixers. Con-Tech Manufacturing, Inc. makes no representation that any replacement parts referred to in this Parts Book are manufactured by McNeilus Truck and Manufacturing, Inc.

Mains, Foldovers, Extensions, and Transitions

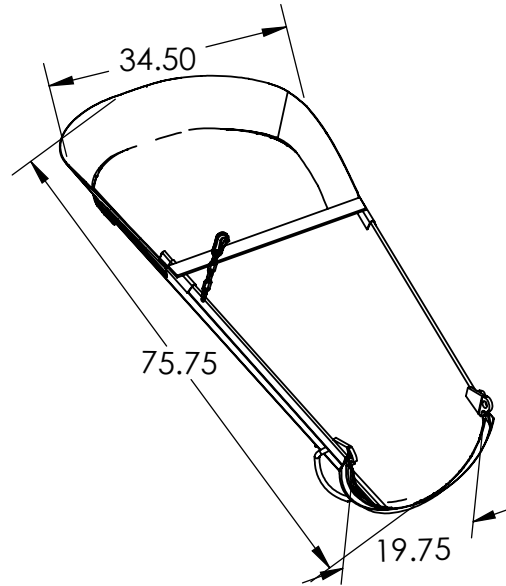
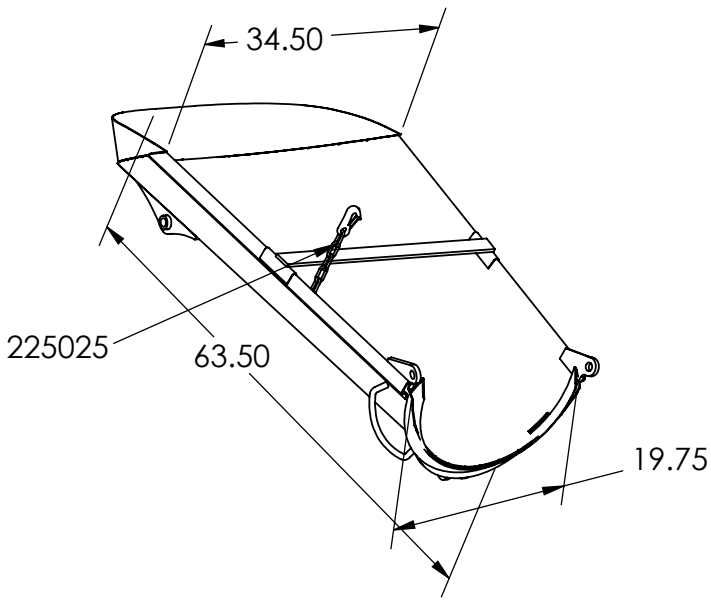

PART #	DESCRIPTION
225025	CHUTE-MAIN SAFETY CHAIN
225181	HP MAIN CHUTE

PART #	DESCRIPTION
225102	6' MAIN CHUTE

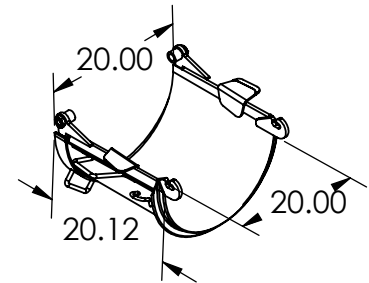
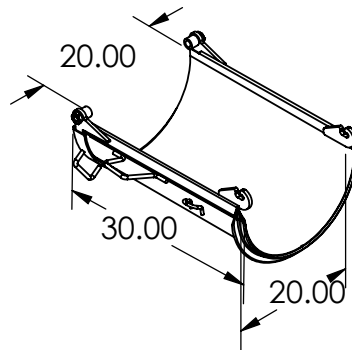
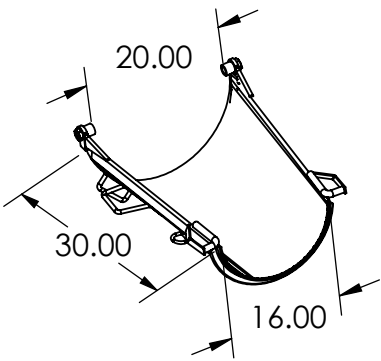

PART #	DESCRIPTION
225030	CHUTE-FOLD OVER

PART #	DESCRIPTION
225049	CHUTE-PAVER FOLD OVER
225076	CHUTE-PAVER F/O SHORT

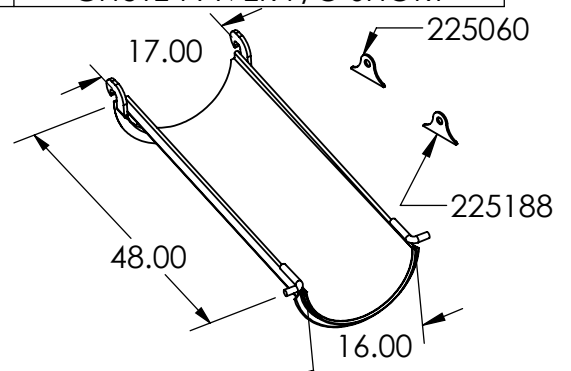
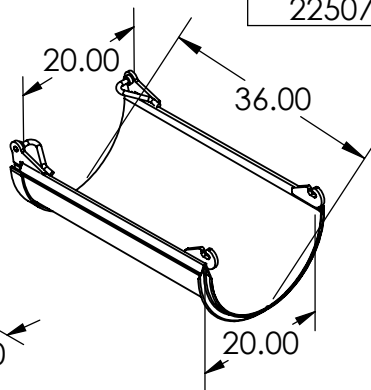
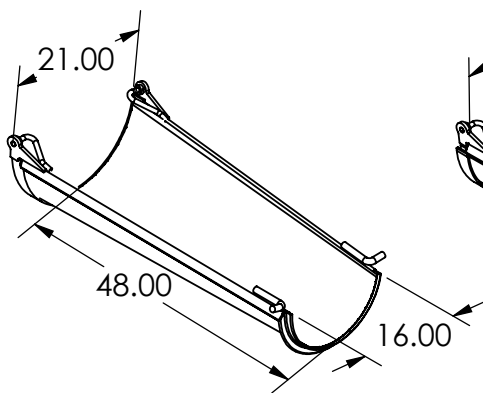

PART#	DESCRIPTION
225053	CHUTE- PAVER TRANSITION
225051	CHUTE PVR EXT

PART#	DESCRIPTION
225001	CHUTE-EXTENSION STL.
770067	CHUTE-EXTENSION ALUM.
225060	EYES HANGING CHUTE STEEL
225188	EYES HANGING CHUTE ALUM

Side Mount Chute Accessories

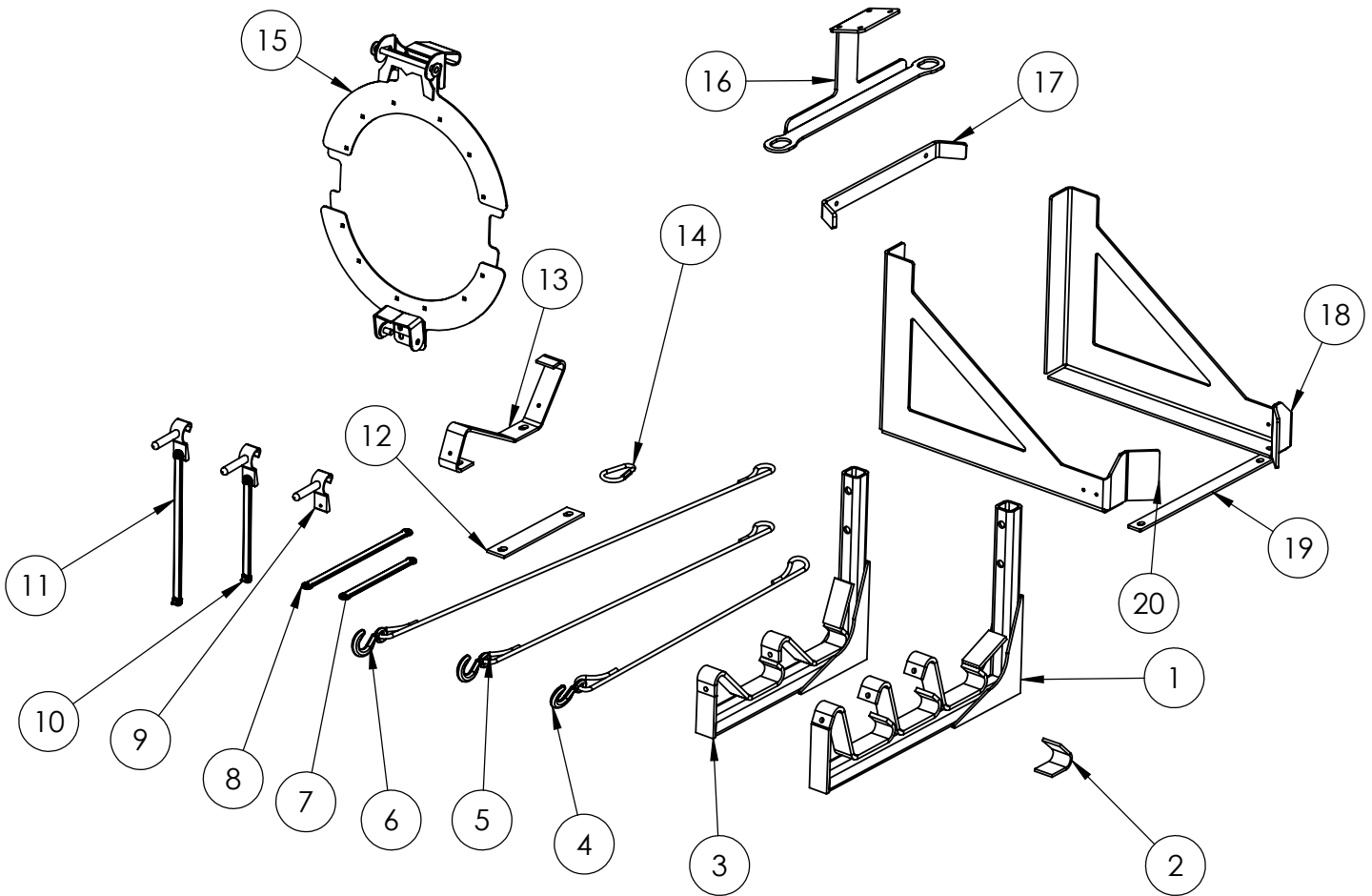

ITEM NO.	PART NUMBER	DESCRIPTION
1	215085	CHUTE RACK-SIDE MOUNT WLDT
2	215312	CHUTE RACK INSERT
3	225130	CHUTE RACK PVR-SIDE MOUNT WLDT
4	780001	CHUTE RACK CABLE 30"
5	780002	CHUTE RACK CABLE 38.5"
6	780003	CHUTE RACK CABLE 47.5"
7	730012	10" RUBBER STRAP
8	730013	15" RUBBER STRAP
9	705002	PLASTIC CHUTE HOLD DOWN HANDLE
10	705004	10" HOLD DOWN WITH HANDLE ASSEMBLY
11	705026	15" HOLD DOWN WITH HANDLE ASSEMBLY
12	285129	BRKT-CHUTE MNT
13	285024	FENDER CHUTE RACK
14	780000	CABLE CONNECTOR LINK
15	225176	CTM ROCK GUARD
16	215092	CHUTE RACK PED MNT STOP
17	225090	SIDE CHUTE BASKET GUIDE
18	225085	SIDE CHUTE BASKET RH
19	225087	SIDE CHUTE BASKET CROSS STRAP
20	225086	SIDE CHUTE BASKET LH

Hanging Chute Accessories

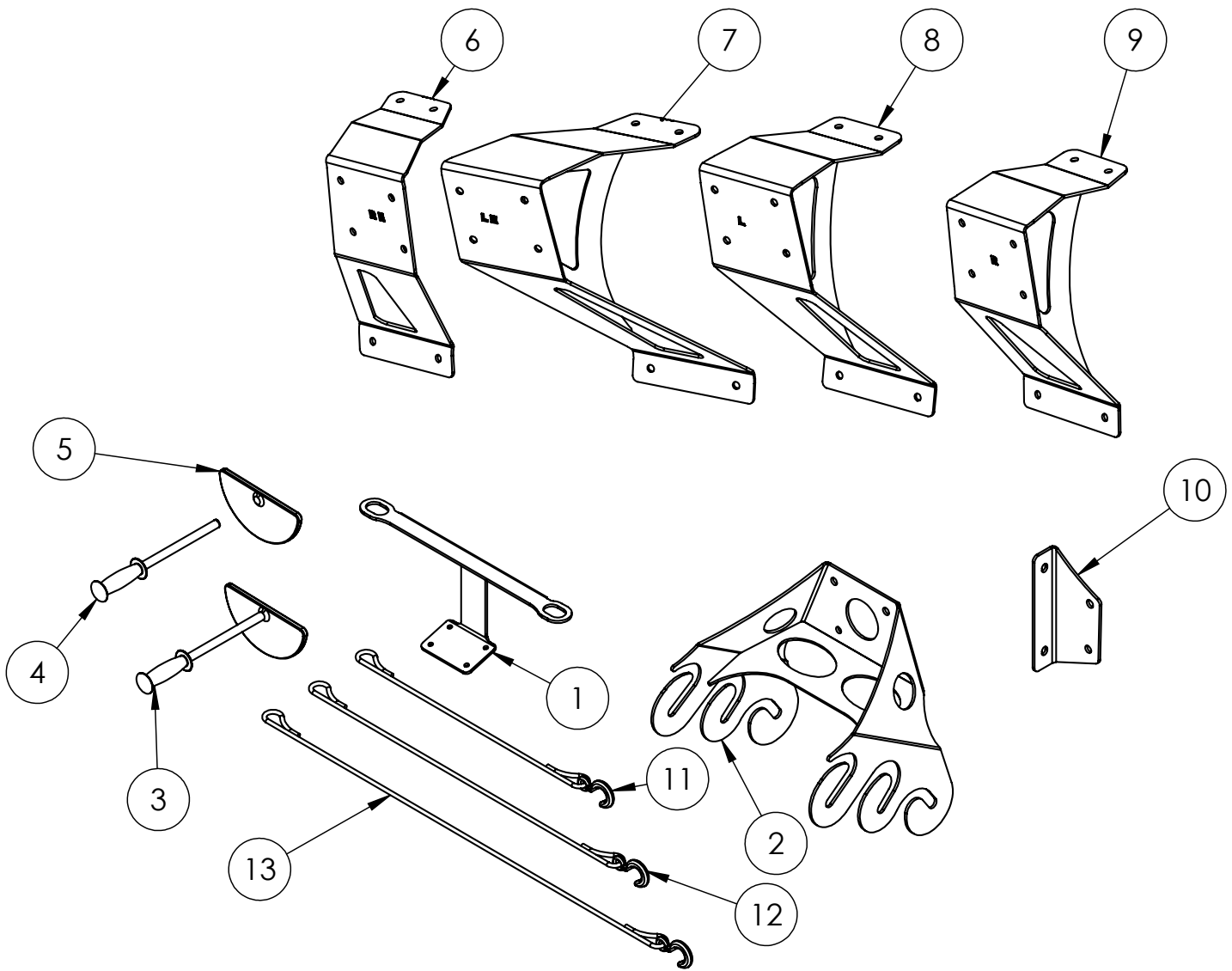

ITEM NO.	PART NUMBER	DESCRIPTION
1	215092	CHUTE RACK PED MNT STOP
2	215094	CHUTE RACK-PED MOUNT
3	730075	CHUTE SCRAPER W/HANDLE
4	730077	CHUTE SCRAPER HANDLE ONLY
5	730076	CHUTE SCRAPER ONLY
6	215500	FRONT RACK MNT OFFSET RH WLDT
7	215478	FRONT RACK MNT OFFSET LH WLDT
8	215476	FRONT CHUTE RACK MOUNT LH WLDT
9	215470	FRONT CHUTE RACK MOUNT RH WLDT
10	215160	CHUTE RACK A PED SETBACK MNT
11	780001	CHUTE RACK CABLE 30"
12	780002	CHUTE RACK CABLE 38.5"
13	780003	CHUTE RACK CABLE 47.5"

Hoppers and Components

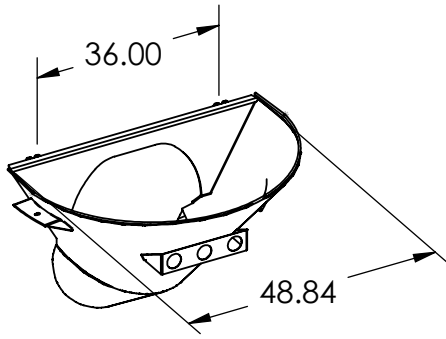

PART #	DESCRIPTION
215191	HP PVR CHARGE HOPPER
215430	HD PVR CHARGE HOPPER

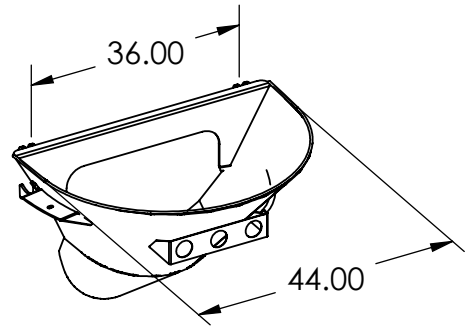

PART #	DESCRIPTION
215277	STD CHARGE HOPPER

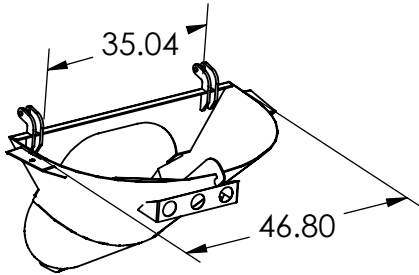

PART #	DESCRIPTION
215503	HP PVR CHARGE HOPPER DROP

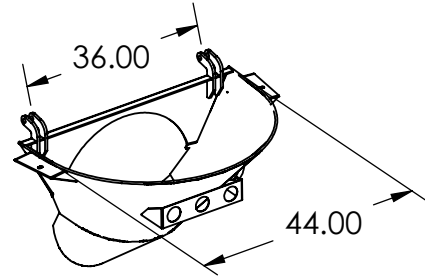

PART #	DESCRIPTION
215346	OS PVR CHARGE HOPPER DROP

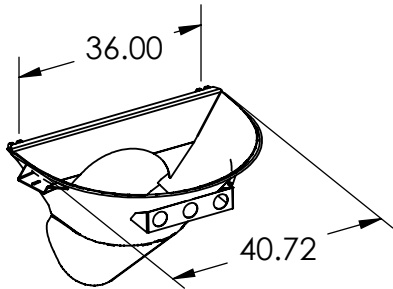

PART #	DESCRIPTION
215070	OS CHARGE HOPPER STD

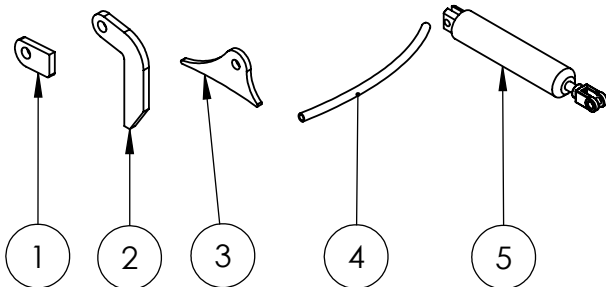
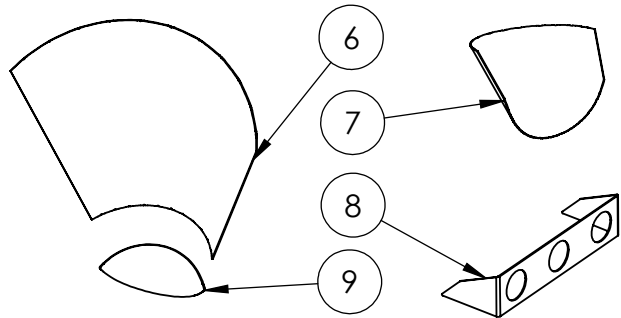

ITEM #	PART #	DESCRIPTION
1	215074	CHARGE HOPPER PIVOT LUG
2	215269	DROP HOPPER PIVOT LUG
3	215076	CHARGE HOPPER CYL LUG
4	215080	LIGHT BAR TUBE
5	750002	CYL, HOPPER AIR LIFT
6	215428	HOPPER BODY LINER
7	215343	CHARGE HOPPER CHUTE LINER
8	215280	STD LIGHT BAR
9	215073	CHARGE HOPPER LINER
NS	760041	MANUAL HOPPER AIR VALVE
NS	730151	HOPPER CYL BOOT
NS	715111	LIGHT HARNESS
NS	715003	2.5" LED LIGHT
NS	715001	2.5 GROMMET
NS	750003	CLEVIS PIN
NS	HAIR PIN	HAIR PIN

Collectors and Bibs

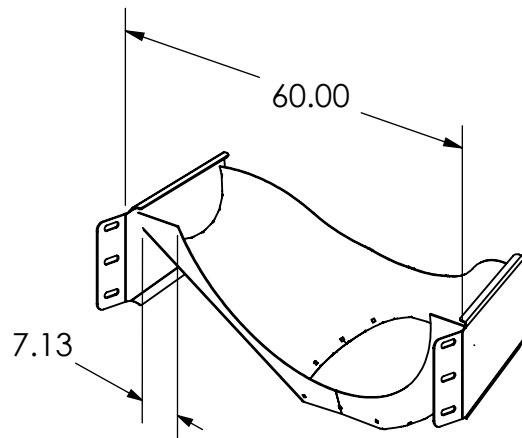
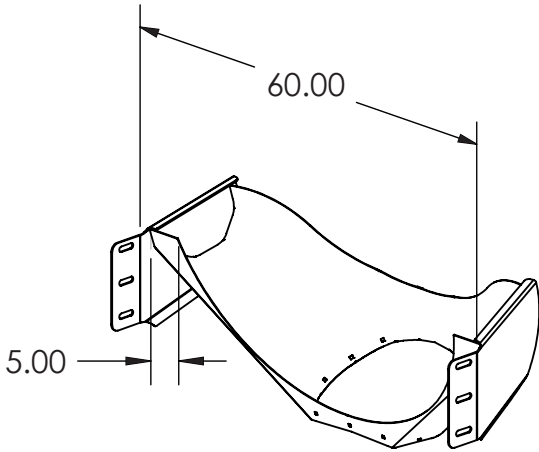

PART #	DESCRIPTION
215060	COLLECTOR HP PVR

PART #	DESCRIPTION
215065	COLLECTOR WIDE STD

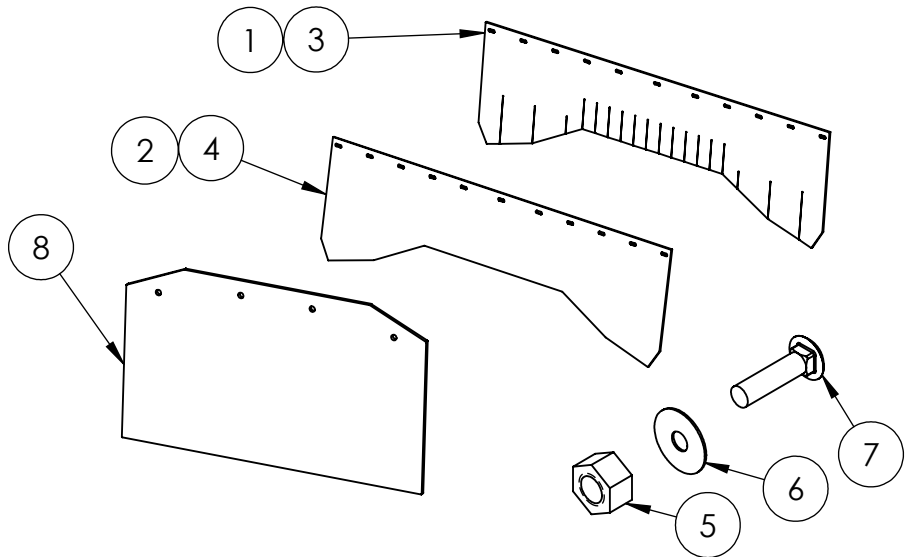
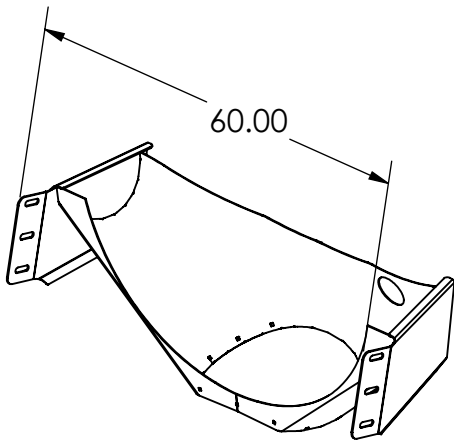

PART #	DESCRIPTION
215571	COLLECTOR FULL BODY

ITEM#	PART #	DESCRIPTION
1	730002	RUBBER III BIB
2	730060	RUBBER BIB W/O SLITS
3	730003	POLY BIB
4	730016	POLY BIB W/O SLITS
5	705007	PLASTIC NUT
6	705006	STAINLESS STL WASHER
7	705051	STAINLESS STL BIB BOLT
8	730010	FILLER MUSTACHE BIB

Rear Pedestals

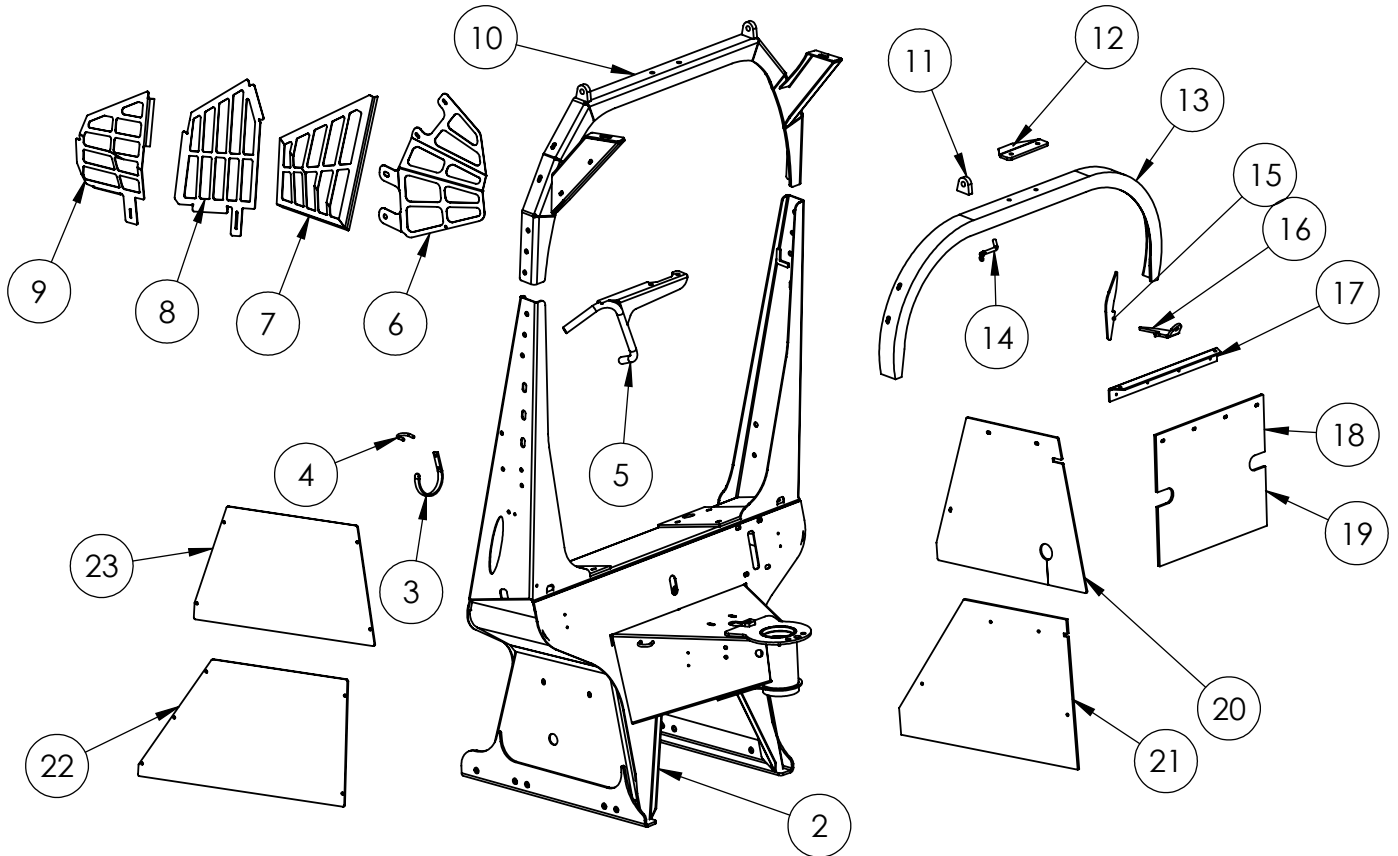

ITEM #	PART #	DESCRIPTION
1	NS	PRE HP PED-CALL FOR DETAILS
2	215515	HP REAR PED-CALL FOR DETAILS
3	215182	HOSE HOOK
4	215208	SPRAYER LOOP
5	215163	WATER INJ TUBE BOLT ON WLDT
6	215752	HP GUARD BOLT ON UPRIGHT
7	215002	GUARD-MIXER
8	215284	GUARD-MIXER PAVER
9	215001	GUARD-MIXER, NON-PAVER
10	215759	HP HOOP WLDT
11	215179	LUG HOPPER PIVOT
12	215159	DRUM DEBOUNCER
13	215177	TOP HOOP ANGLE
14	705093	SAFETY PROP PIN W/COTTER PIN
15	215170	TOP HOOP GUSSET
16	215178	MOUNT HOPPER CYL
17	215418	REAR PED BACK FLAP BRKT
18	215416	REAR PED BACK FLAP
19	215417	REAR PED BACK FLAP 9YD
20	215236	COVER-BRAKE VAVLE REAR PED
21	215450	COVER-BRAKE VAVLE REAR B PED
22	215788	VALVE COVER- FLAP TYPE B
23	215787	VALVE COVER- FLAP TYPE A

*** FOR COMPLETE MTM PED REPLACEMENT CALL FOR DETAILS**

Rear Pivot Assembly

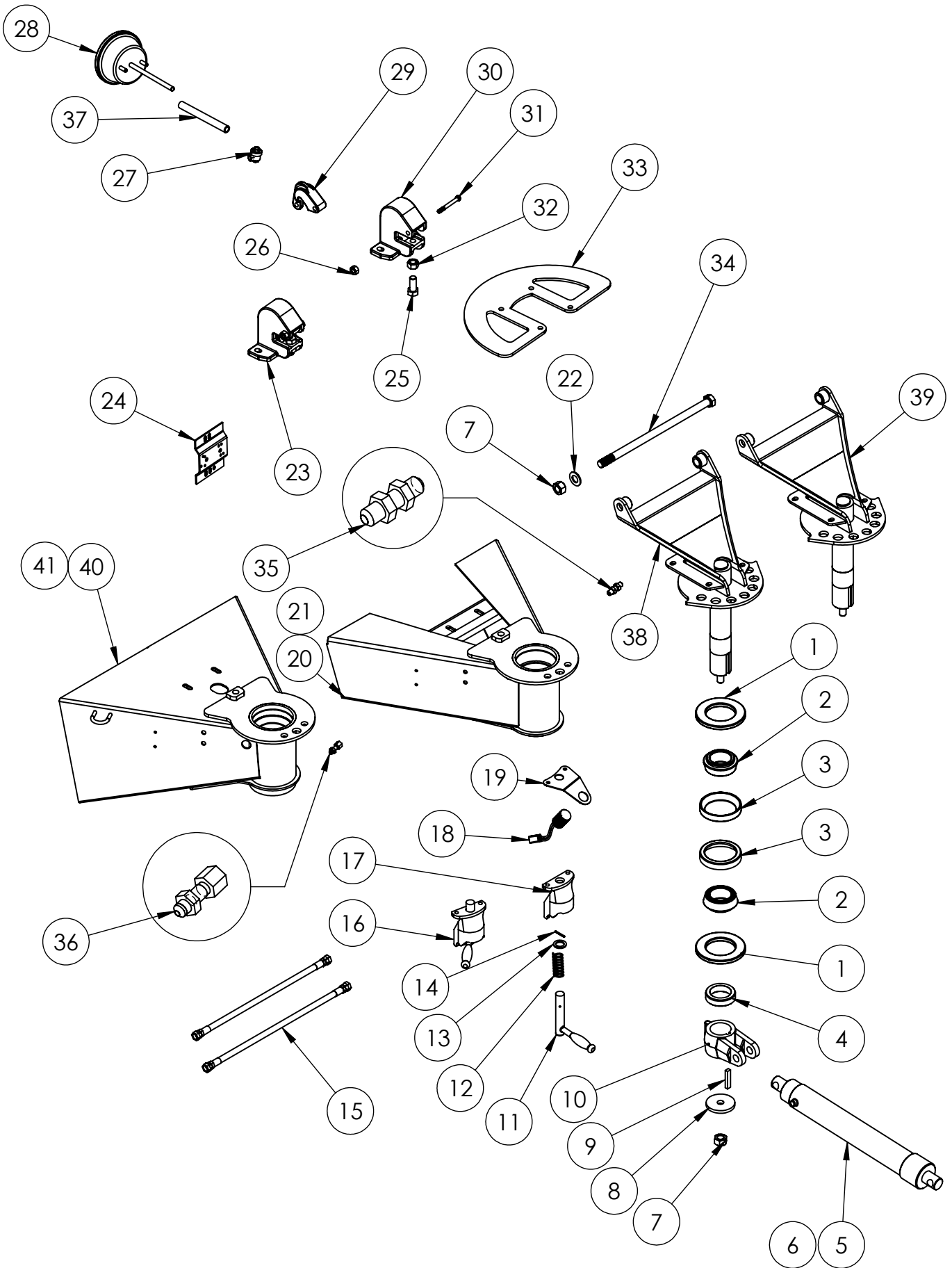

Rear Pivot Assembly

ITEM #	PART #	DESCRIPTION
1	725014	SEAL-SWIVEL BEARING
2	720005	CONE, ROLLER BEARING
3	720006	ROLLER BEARING CUP
4	215116	MAIN PIVOT LOWER SEAL RING
5	750000	CYL-CHUTE LIFT, SINGLE ACT
6	750001	CYL-CHUTE LIFT,DOUBLE ACT
7	3/4" LK NUT	7/8" UNC LOCK NUT
8	215110	MAIN PIVOT WASHER
9	215261	CHUTE CYL CLEVIS KEY
10	770004	CHUTE CLEVIS- CAST
11	770009	CHUTE LOCK CAST HANDLE
12	705034	CHUTE LOCK SPRING
13	705036	WASHER-CHUTE LOCK
14	705035	ROLL PIN 5/32" X 1-1/2"
15	730052	CHUTE LIFT CYL KIT
16	770003	MANUAL CHUTE LOCK ASSY
17	770008	CHUTE LOCK CAST BODY
18	715008	PROX SWITCH
19	215143	MAIN PROX MOUNT
20	215128	REAR PIVOT HOUSING A
21	215129	REAR PIVOT HOUSING B
22	FW 0.875	7/8" FLAT WASHER
23	770007	CHUTE LOCK CLAMP ASSY
24	215185	VALVE MOUNT MAC
25	3/4" BOLT	3/4"-10 UNC X 1 3/4 GR-5
26	1/2" HEX NUT	1/2"-13 UNC HEX
27	760300	CHUTE LOCK QUICK DUMP VALVE
28	785002	#16 BRAKE CAN
29	770006	CHUTE LOCK CAM CLAMP
30	770005	CHUTE CLAMP BASE
31	3/8" BOLT	3/8"-16 UNC X 3 1/2 GR-5 HEX BOLT
32	3/4" NUT	NUT-3/4"-10 UNC HEX
33	215103	DISC REAR BRAKE PLATE
34	PIVOT BOLT	7/8-9 UNC X 18" HEX BOLT GR-8
35	# 6 BULK HEAD	#6 BULK HEAD FITTING
36	#4 BULK HEAD	#4 BULK HEAD FITTING
37	215623	CHUTE LOCK TUBE
38	215633	PRE-HP MAIN PIVOT ASSY
39	215664	HP MAIN PIVOT ASSY SHORT
40	215781	HP A PIVOT HOUSING WLDT
41	215782	HP B PIVOT HOUSING WLDT

Rollers

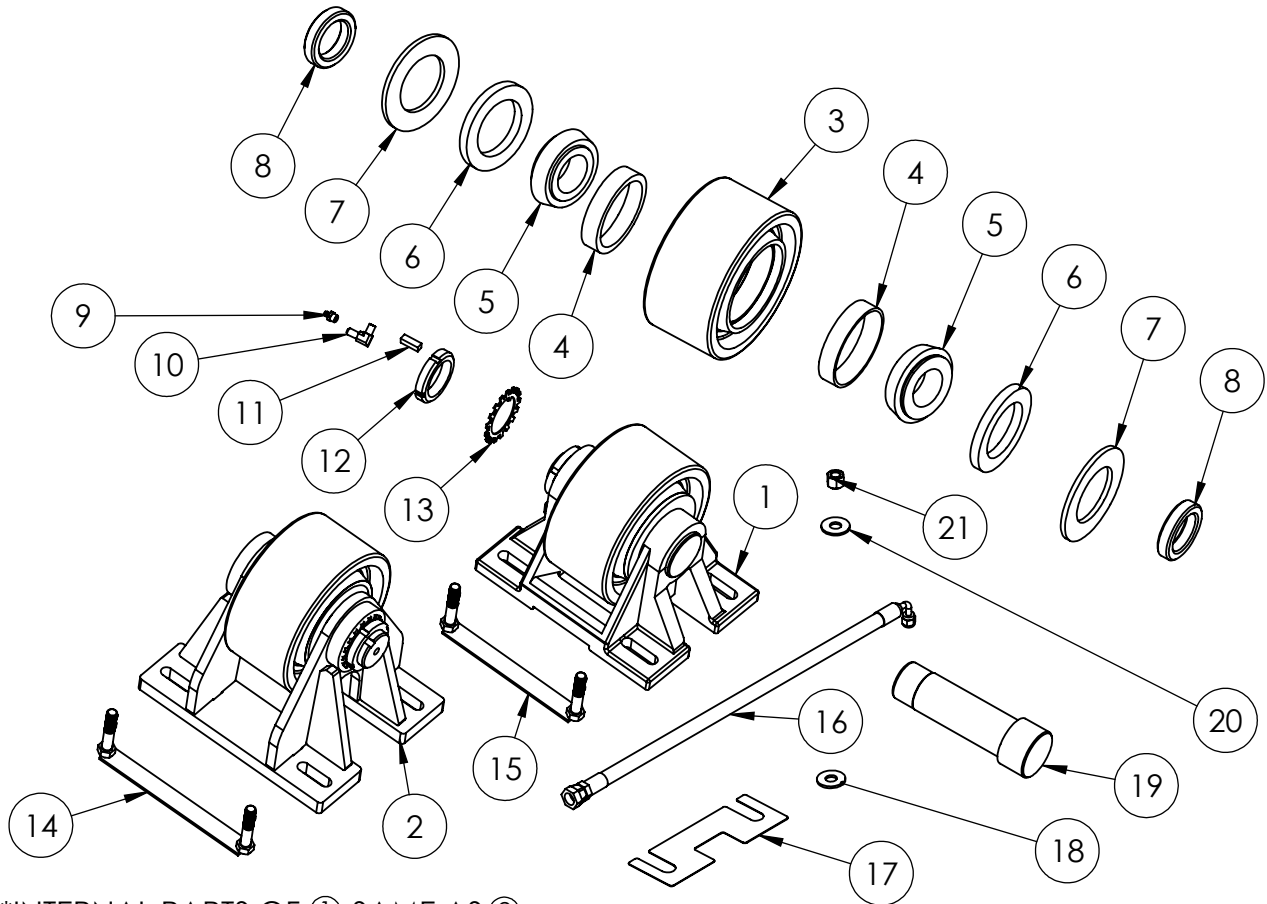

*INTERNAL PARTS OF ① SAME AS ②

ITEM NO.	PART NUMBER	DESCRIPTION	QTY.
1	755000	OLD CTM/MTM ROLLER ASSY AND BRACKET	1
2	755015	ROLLER BRACKET ASSY (NEW)	1
3	755002	DRUM ROLLER	1
4	720003	ROLLER BEARING CUP	2
5	720004	CUP, ROLLER BEARING	2
6	725013	SEAL,OIL	2
7	725012	SEAL, FELT	2
8	720000	SPACER, ROLLER	2
9	710003	FITTING,1/8" NPT GREASE	1
10	90 FITTING	90 FITTING	1
11	755004	.3125 X .3125 X 1" KEY	1
12	705003	NUT,LOCK #10 (N-10)	1
13	705005	WASHER,LOCK #10	1
14	285527	HP ROLLER BOLT BRACKET ASSY	1
15	285506	SHORT ROLLER - BOLT BRACKET	1
16	755003	REMOTE GREASE LINES	1
17	720009	SHIM-ROLLER 0.036"	1
18	FW 0.5	WASHER, HARDENED 1/2" FLAT	1
19	775002	SHAFT-ROLLER	1
20	FW 0.5	WASHER, FLAT 1/2"	1
21	1/2" NUT	NUT-LOCK 1/2"-13UNC GRD 8	1

HP Ladders and Platforms

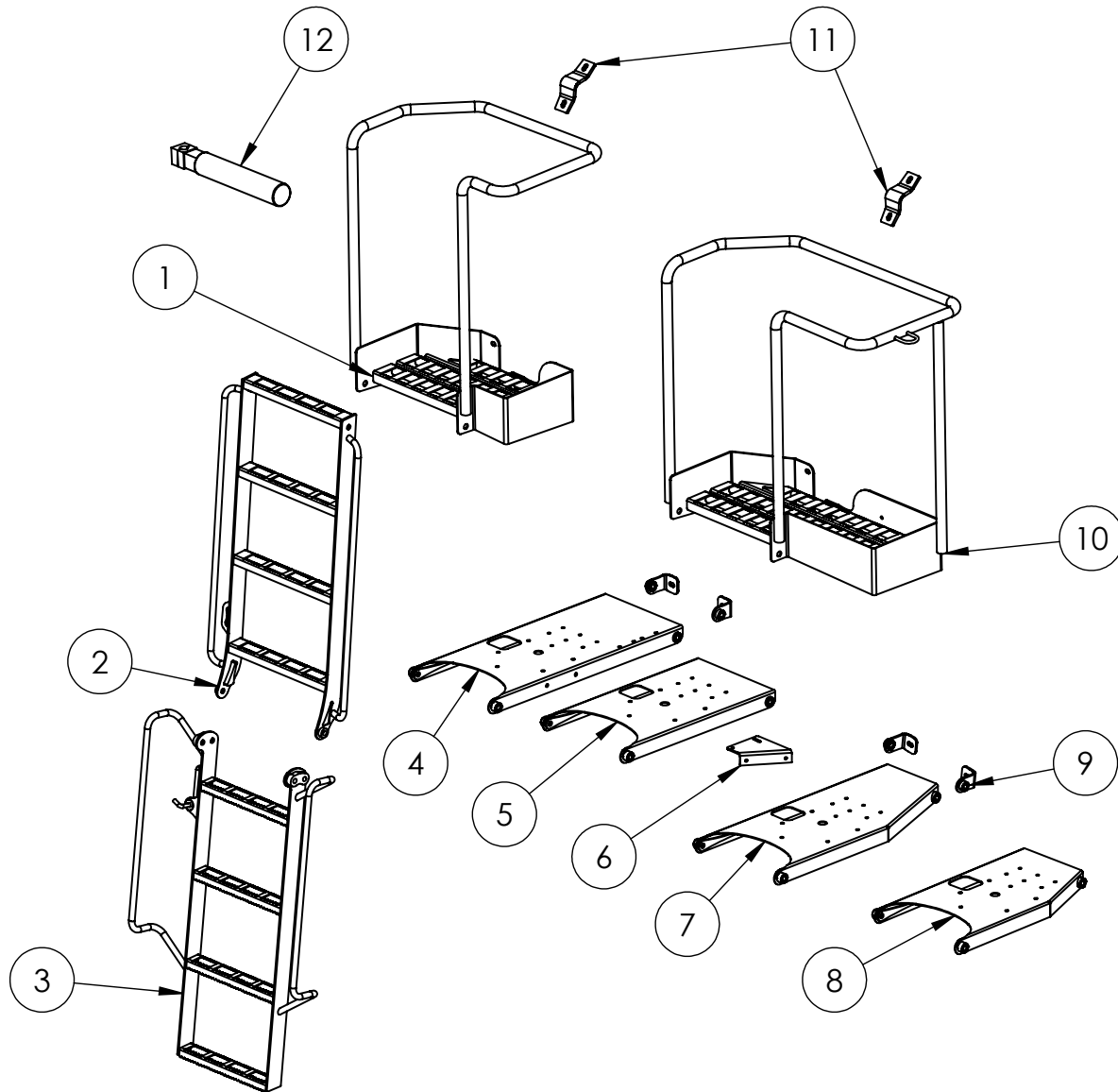

ITEM #	PART #	DESCRIPTION
1	215796	HP BOLT ON UPPER PLATFORM W/RAIL
2	215673	UPPER LADDER ASSY
3	215672	LOWER LADDER ASSY
4	215646	LOWER LADDER PLATFORM , HP A-PED WLDT
5	215681	HP LOWER LADDER PLATFORM, O/S A-PED
6	215734	REAR CONTROL MNT BRKT
7	215710	LOWER LADDER PLATFORM, HP B- PEDESTAL
8	215712	HP LOWER LADDER PLATFORM, O/S B-PED
9	215678	HP PLATFORM MOUNT LUG
10	215797	HP EXTENDED UPPER PLATFORM W/RAIL
11	215357	BOLT ON HAND RAIL OVERLAY
12	799810	MAN SAVER BAR ASSY

Ladders and Platforms

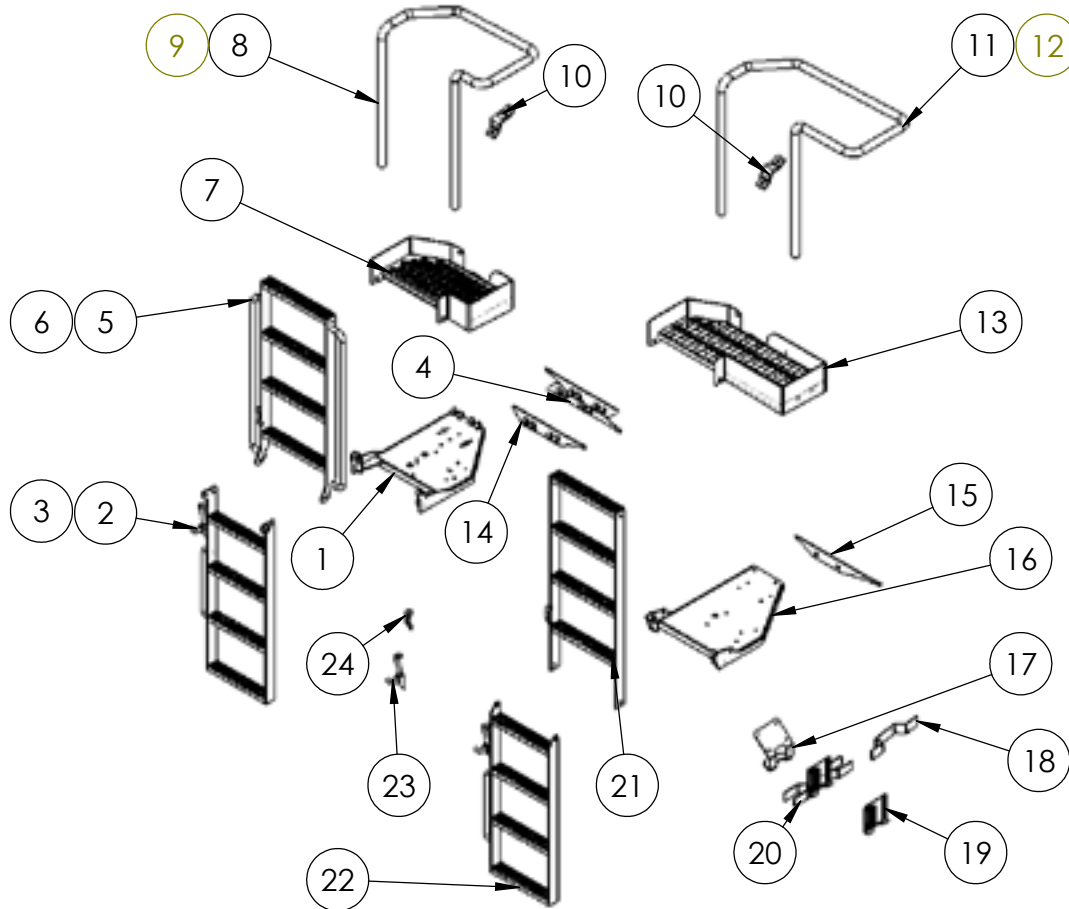

ITEM #	PART #	DESCRIPTION
1	215028	LOWER LADDER PLATFORM
2	215039	LOWER LADDER W/LATCH
3	215369	9 YD LOWER LADDER
4	215068	PLATFORM MOUNT A
5	215035	UPPER LADDER
6	215368	9 YD UPPER LADDER
7	215356	STD BOLT ON UPPER PLTFM WLDT
8	215082	RAILING UPPER PLATFORM PVR/HP
9	215012	RAILING UPPER PLATFORM STD
10	215357	BOLT ON PLTFM RAILING MNT
11	215274	RAILING UPPER PLATFORM PVR EXTENDED
12	215302	RAILING UPPER PLATFORM STD EXTENDED
13	215460	EXTENDED UPPER PLATFORM WLDT
14	215041	PLATFORM MOUNT B
15	215009	PLATFORM MOUNT
16	215003	LOWER LADDER PLATFORM (OLD STYLE)
17	215375	PENDANT HOLDER ANGLED BRKT
18	215130	PENDANT CORD RAP FENDER MNT
19	215047	PENDANT HOLDER
20	215050	PENDANT HOLDER W/WRAP
21	215015	UPPER LADDER (OLD STYLE)
22	215017	LOWER LADDER W/LATCH (OLD STYLE)
23	215022	LADDER LATCH
24	215034	LADDER LATCH MOUNT

Front Pedestal

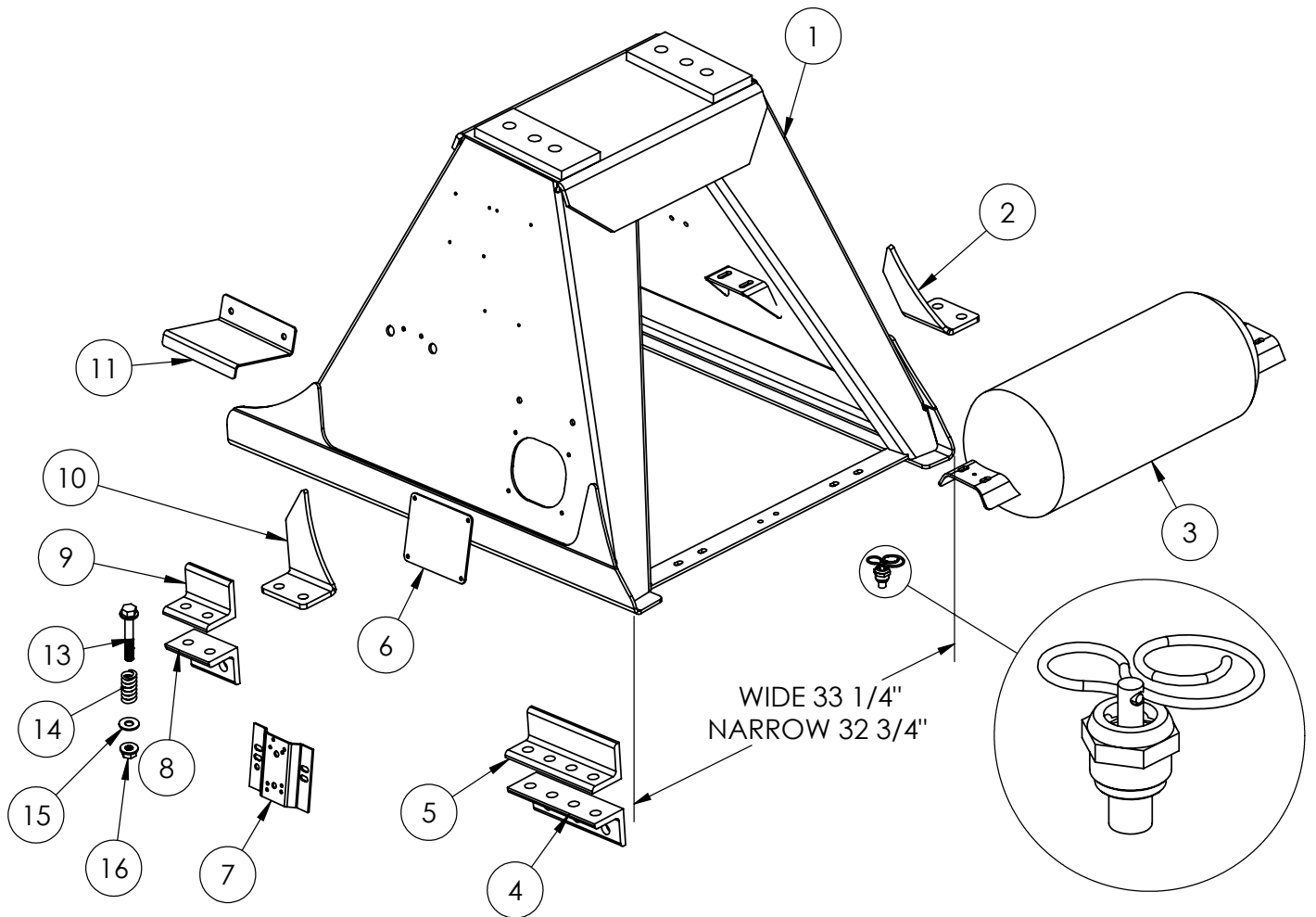

ITEM #	PART #	DESCRIPTION
1	CTM	FRONT PED-CALL FOR DETAILS
2	215258	FRONT PED BM CLIP LH
3	785100	AUXILARY AIR TANK
4	215152	FRAME CLIP 7 HOLE LONG
5	215150	FRAME CLIP 4 HOLE LONG
6	215297	PLATE,FRONT PED COVER
7	215185	VALVE MOUNT MAC
8	215153	FRAME CLIP 4 HOLE SHORT
9	215151	FRAME CLIP 2 HOLE
10	215257	FRONT PED BM CLIP RH
11	215081	MAC VALVE MANIFOLD COVER
12	BOLT	BOLT 4.5"
13	SPRING	SPRING 2.3" LONG
14	WASHER	WASHER 9/16"
15	NUT	NUT 9/16"
16	760040	1/4" DRAIN VALVE W/ 48" CABLE

Air Systems

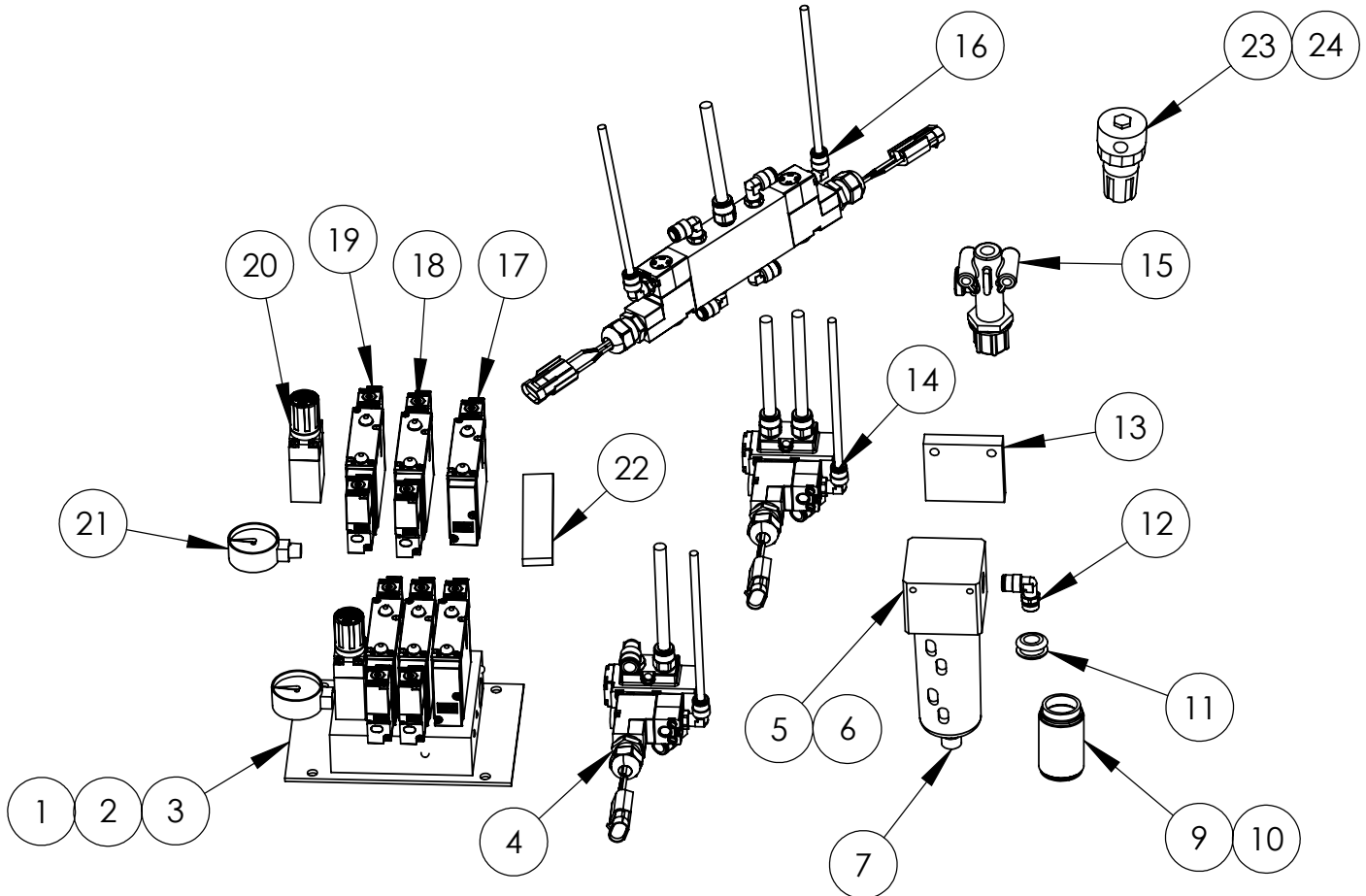

ITEM #	PART #	DESCRIPTION
1	760075	CHUTE LOCK MAC VALVE ASSY
2	760085	CHUTE LOCK/HOPPER MAC VALVE ASSY
3	760080	CHUTE LOCK/HOPPER/AXLE MAC VALVE ASSY
4	760032	CHUTE LOCK MAC VALVE (OLD STYLE)
5	735004	COALESCING FILTER ASSY (CAMOZZI)
6	735015	COALESCING FILTER ASSY (PARKER)
7	735018	COALESCING FILTER DRAIN (PARKER)
NS	735016	COALESCING FILTER BOWL(PARKER)
9	735006	COALESCING FILTER ELEMENT(CAMOZZI)
10	735017	COALESCING FILTER ELEMENT(PARKER)
11	725008	3/4" GROMMET
12	AIR FITTING	3/8" AIR FITTING 90°
13	285258	COALESCING FILTER SPACER
14	760033	HOPPER MAC VALVE (OLD STYLE)
15	760023	HOLD BACK VALVE
16	760034	PUSHER MAC VALVE (OLD STYLE)
17	760052	CHUTE LOCK MAC VALVE ONLY
18	760053	HOPPER MAC VALVE ONLY
19	760054	AXLE MAC VALVE ONLY
20	760055	MAC VALVE REGULATOR
21	760056	0-100 PSI PRESSURE GAUGE
22	760057	BLOCK OFF PLATE
23	760020	0-60 AIR REGULATOR
24	760035	0-12 AIR REGULATOR

Gear Boxes

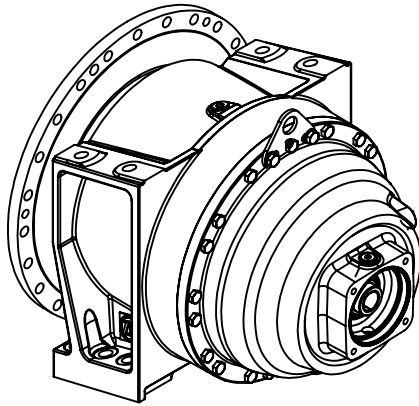

P7300

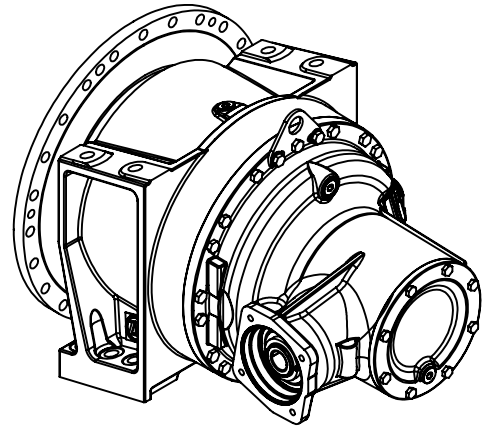

PK7500

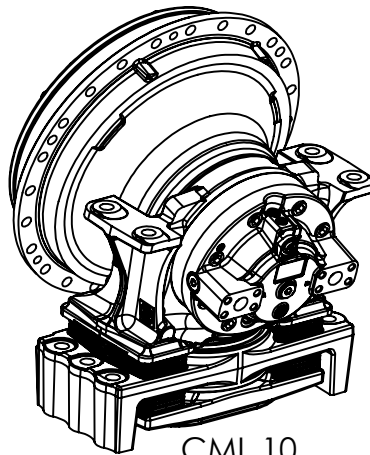

CML 10

PART #	DESCRIPTION
748008	ZF P7300 DRIVE
748009	ZF PK7500 DRIVE
748010	ZF CML 10 DRIVE
745002	ZF "P" RESEAL
745003	ZF "P" REMANUFACTURED
745004	ZF "PK" RESEAL
745005	ZF "PK" REMANUFACTURED
745500	MAIN SEAL
745508	OUT PUT BEARING
705100	OUT PUT FLANGE NUT
745501	MAIN HOUSING GASKET
745503	DIP STICK-VENTED
745507	DIP STICK-PLASTIC
745506	SITE GLASS-PLASTIC
745012	MAIN HOUSING O-RING
748011	CML 10 SENSOR
730601	GEAR LUBE ECO MIX X (CML ONLY)
PUSH BOLT	3/4" BOLT
PUSH BOLT	16 MM

Fan Coolers

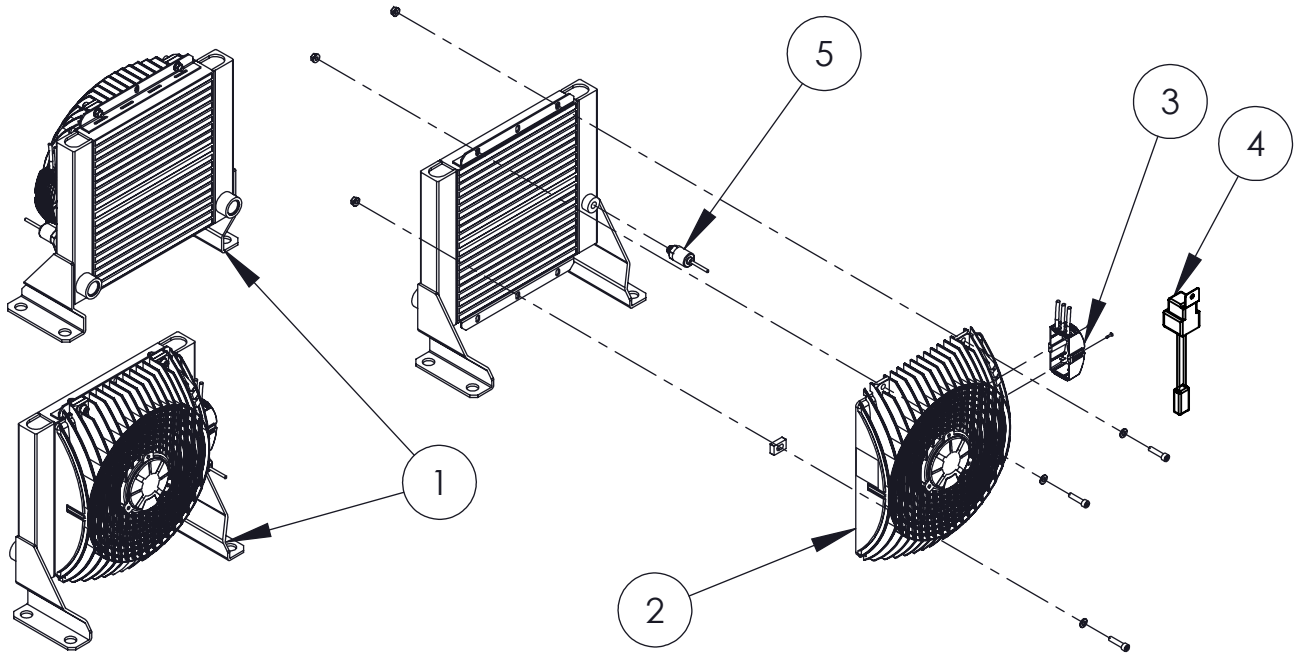

CTM HIGH PERFORMANCE COOLER

ITEM #	PART #	DESCRIPTION
1	740010	COMPLETE ASA ASSY
2	740009	FAN/MOTOR ASA ASSY
3	740011	CONTROLLER-OLD STYLE
4	715154	FAN CONTROL RELAY ASSEMBLY- NEW STYLE
5	740013	NEW TEMP. SWITCH 3/4" NPT W/BRASS WASHER SEAL

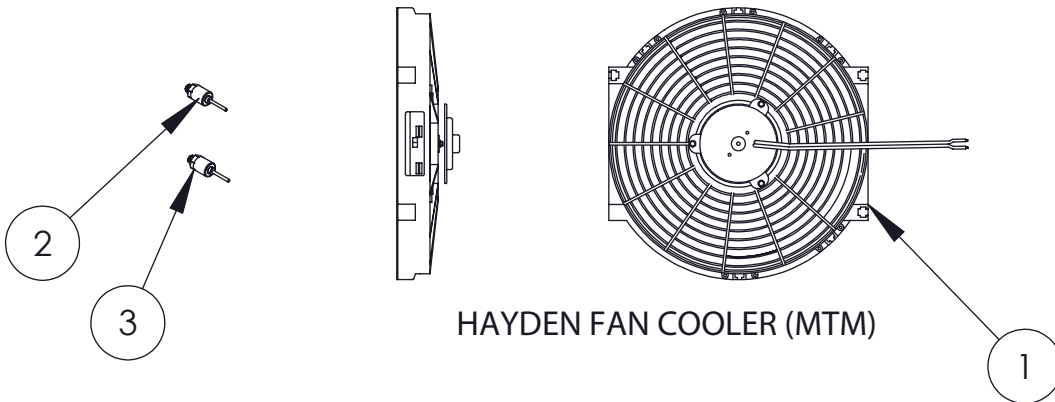

HAYDEN FAN COOLER (MTM)

ITEM #	PART #	DESCRIPTION
1	715014	HAYDEN FAN MOTOR ASSY
2	715015	UPPER TEMP SWITCH 180°
3	715016	LOWER TEMP SWITCH 140°

Hydraulic Cylinders, Pins, & Bushings

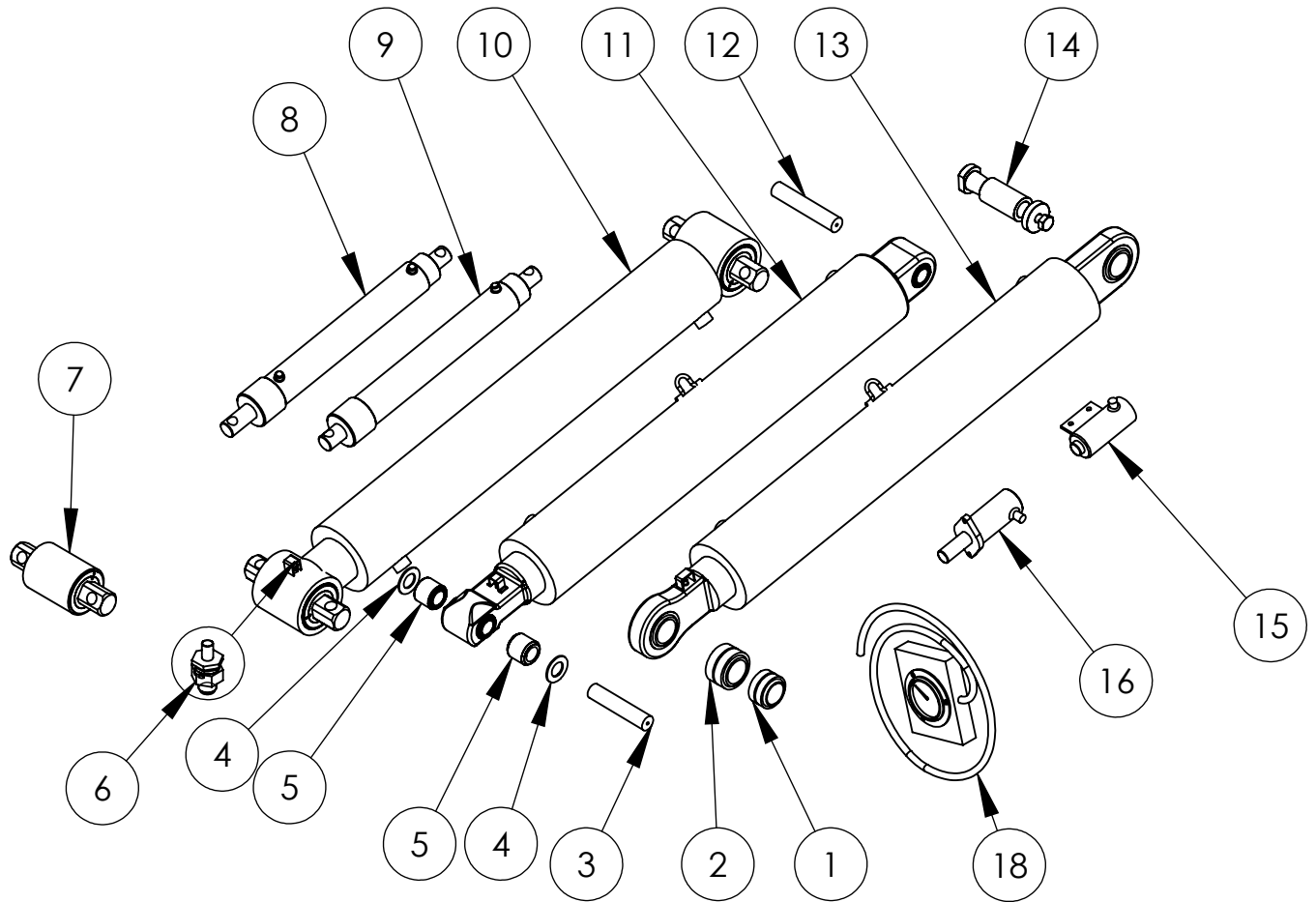

ITEM #	PART #	DESCRIPTION
1	720002	BEARING SPHERICAL 2"
2	720008	BEARING SPHERICAL 2 1/4"
3	775010	AXLE CYL PIVOT PIN 6 5/8"
4	720032	THRUST WASHER
5	720014	MTM BMV CYL BUSHING
6	725036	NITROGEN FILL VALVE
7	750051	BRIDGEKING PIVOT BUSHING
8	750001	CYL-CHUTE LIFT,DOUBLE ACT
9	750000	CYL-CHUTE LIFT, SINGLE ACT
10	750050	BRIDGEKING CYL
11	750011	REBUILT MTM BMV CYL
12	775011	AXLE CYL PIVOT PIN 7 5/16"
13	750012	REBUILT MTM BMIII CYL 2 1/4"
14	705200	2 1/4" THUMBPIN
15	750060	BRIDGEKING LATCH CYL
16	750004	MTM BMV LATCH CYL
17	730150	BRIDGE CYLINDER BOOT KIT
18	730161	CHUTE CYL BOOT KIT
NS	750005	ACCUMULATOR CHARGE KIT
NS	730150	SEAL SAVER - BK CYLINDER
NS	730161	SEAL SAVER - CHUTE CYLINDER

Hydraulic Pumps and Motors

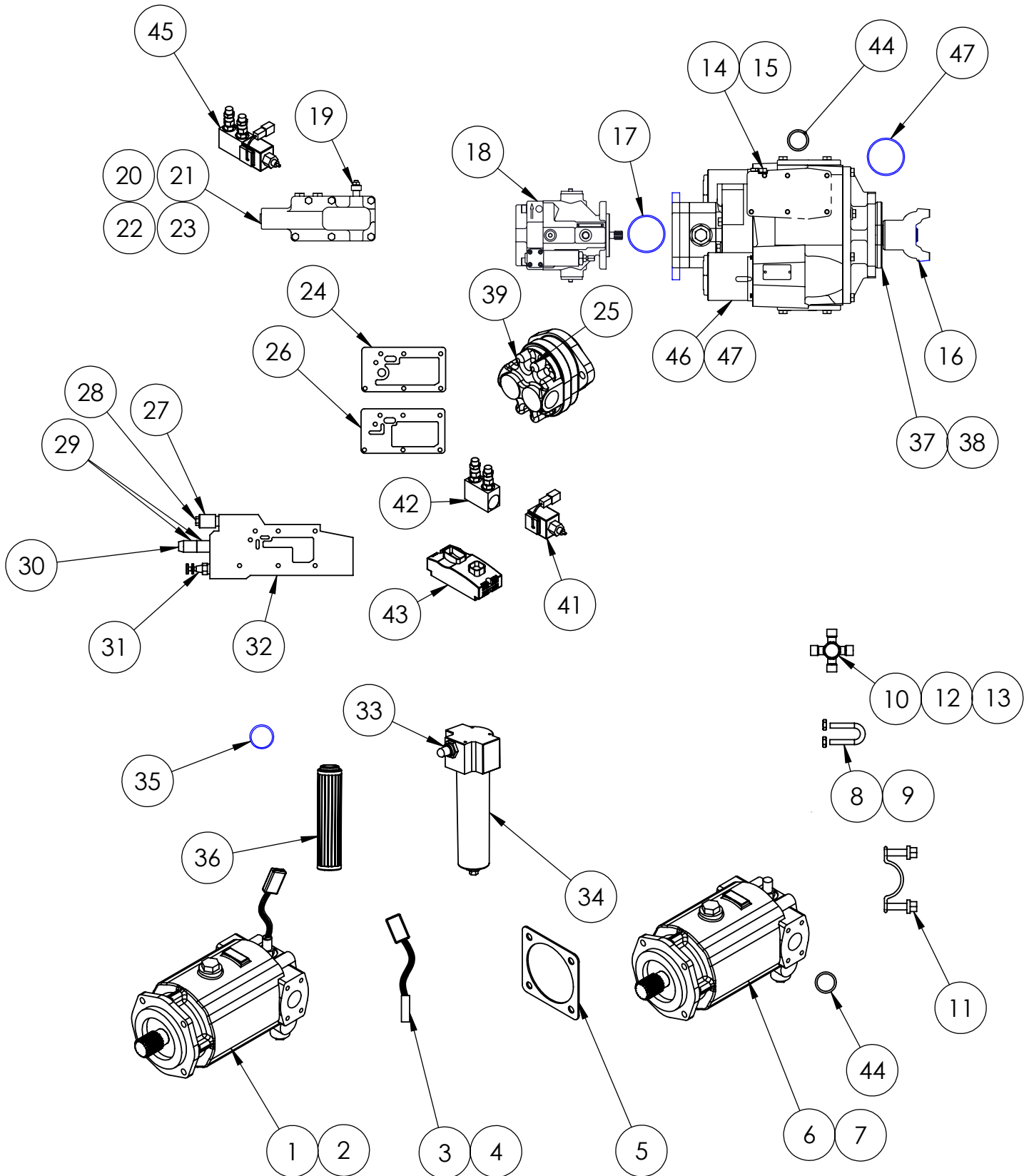

Hydraulic Pumps and Motors

ITEM #	PART #	DESCRIPTION
1	745453	EATON MOTOR 3 WIRE (5433-059)
2	745452	EATON MOTOR 4 WIRE (5433-129)
3	740028	3-WIRE SENSOR (CONSTANT SPEED)
4	740029	4-WIRE QUAD SENSOR
5	725017	MOUNTING MOTOR GASKET
6	745450	EATON MOTOR (4633-047)
7	745451	EATON MOTOR (5433-043)
8	795005	1350 U-BOLT KIT
9	795000	1310 U-BOLT KIT
10	795002	1310 U-JOINT
11	795014	1350 STRAP KIT
12	795003	1350 U-JOINT
13	795004	1310-1350 U-JOINT CONVERSION
14	745420	EATON PUMP-RH A-PAD (5423-833) (MANUAL)
15	745415	EATON PUMP-RH A-PAD(5423-925)-(ELECTRONIC)
16	795006	1350 SERIES PUMP YOKE
17	725021	PARKER PUMP O-RING
18	745300	PARKER PUMP-RH
19	725022	MANUAL CONTROL VALVE SHAFT
20	725024	CONTROL VALVE ASSY (NEW)
21	725023	CONTROL VALVE ASSY (REBUILT)
22	725026	MANUAL CONTROL VALVE,RE,NEW
23	725027	MANUAL CONTROL VALVE,RE,REBUILT
24	725002	STD CONTROL VALVE-GASKET KIT AND EP
25	745301	RH A-PAD GEAR PUMP
26	740005	GASKET-RE CONTROL VALVE (RE ONLY)
27	740016	COIL-RE START/STOP
28	740015	CARTRIDGE-RE START/STOP
29	740018	COIL (2)- RE CHARGE/DISCHARGE
30	740017	CARTRIDGE-RE CHARGE/DISCHARGE
31	740019	CARTRIDGE-MANUAL OVERRIDE
32	725007	RE CONTROL VALVE ASSY
33	760037	BY-PASS INDICATOR
34	735010	PARKER HIGH PRESSURE FILTER ASSY
35	725019	HIGH PRESSURE FILTER O-RING
36	735003	HIGH PRESSURE FILTER ELEMENT
37	725015	INPUT/OUTPUT SHAFT SEAL KIT-LIP STYLE
38	725001	INPUT/OUTPUT SHAFT SEAL KIT-MECHANICAL
39	745302	LH A-PAD GEAR PUMP
40	760192	CONSTANT SPEED CONTROL CARTRIDGE
41	760191	CONSTANT SPEED CONTROL COIL
42	760193	CONSTANT SPEED CONTROL MANIFOLD
43	760190	CONSTANT SPEED CONTROLLER
44	725018	SPLIT FLANGE O-RING
45	760000	VALVE- DRUM START STOP ASSY
46	725004	O RING LARGE SERVO CAN
47	725000	SMALL SERVO CAN O-RING/TRUNION
NS	730050	15 FT EMERGENCY JUMPER HOSE KIT

BridgeKing Control Manifold

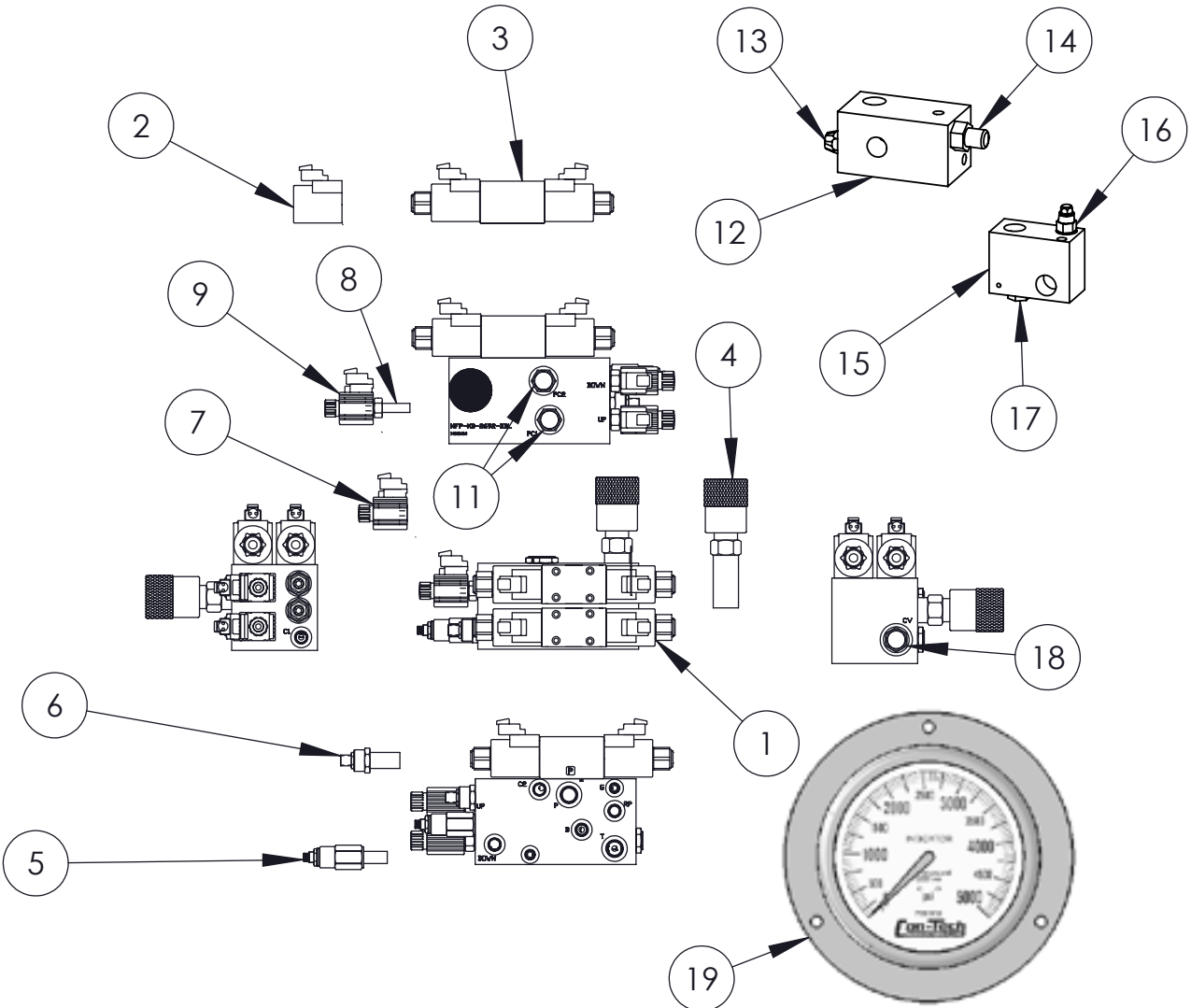

Standard Mixer Chute Lift Manifold

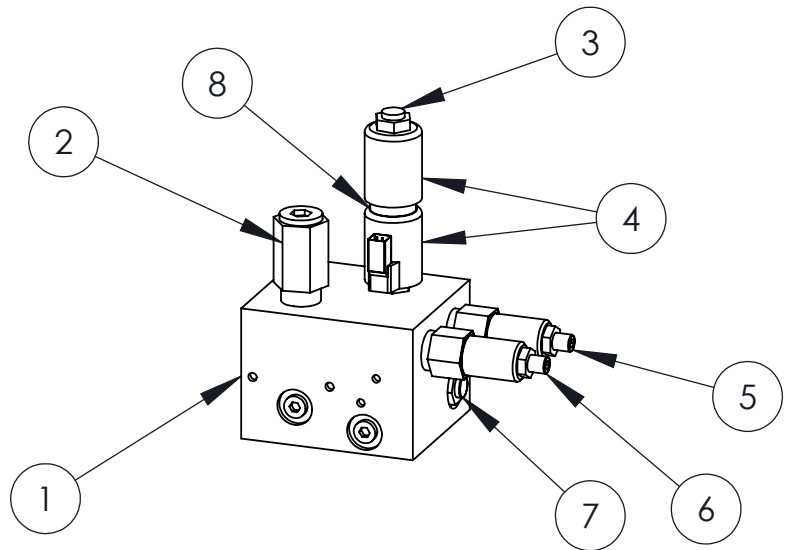

BridgeKing Control Manifold

ITEM #	PART #	DESCRIPTION
1	760154	CTM COMBO BLOCK
1A	760402	MTM COMBO BLOCK(NOT SHOWN)
2	760156	CTM COIL ONLY-PARKER VALVE
2A	715000	MTM COIL ONLY (NOT SHOWN)
3	760158	CTM PARKER VALVE/AXLE STOP VALVE
3A	760015	MTM PARKER VALVE(NOT SHOWN)
4	760027 *	AXLE PRESSURE ADJUSTING VALVE
5	760159 *	CHUTE FLOW CONTROL - DOWN
6	760160 *	CHUTE FLOW CONTROL-UP
7	760165	COIL ONLY - CHUTE UP/DOWN
8	760167	CARTRIDGE CHUTE UP/DN WITH OVERRIDE
9	760166	CTM CARTRIDGE & COIL-CHUTE UP/DOWN
9A	760028	MTM CARTRIDGE & COIL(NOT SHOWN)
10	760168	CARTRIDGE & COIL CHUTE UP/DN WITH OVERRIDE
11	760095 *	PILOT OP CHECK VALVE-CHUTE UP/DOWN
12	760403 *	CYL CONTROL BLOCK-FRONT
13	760163 *	PILOT TO SHIFT VALVE
14	760162 *	3300 PSI RELIEF VALVE
15	760155 *	CYL CONTROL BLOCK REAR
16	760157	COUNTERBALANCE VALVE
17	760161	CHECK VALVE (5 PSI)
18	760161	CHECK VALVE -TANK DRAIN
19	760024 *	0-5000 AXLE PRESSURE GAUGE
NS	760027	VALVE PRV 2 O-RING KIT
NS	725029	O-RING PARKER VALVE MOUNT
NS	705060	SCREW - SHORT PARKER VALVE
NS	705061	SCREW -LONG PARKER VALVE
NS	740004	BLOCK OFF PLATE - PARKER VALVE

* PARTS INTERCHANGEABLE FOR MTM (BMV) / ITEM #A MTM SPECIFIC

Standard Mixer Chute Lift Manifold

ITEM #	PART #	DESCRIPTION
1	765100	CHUTE LIFT MANIFOLD ASSY- DBL ACT
1A	760101	OPEN CENTER SINGLE ACTING
2	765095	2200 PSI RELIEF VALVE
3	765092	CARTRIDGE ONLY-RAISE/LOWER
4	765093	COIL ONLY-RAISE/LOWER (2)
5	765097	DOWN FLOW CONTROL
6	765091	UP FLOW CONTROL
7	765096	PILOT OP CHECK VALVE
8	765094	COIL SPACER

* THIS MANIFOLD ASSY CAN BE USED WITH ANY STANDARD MIXER

BridgeKing Trailer

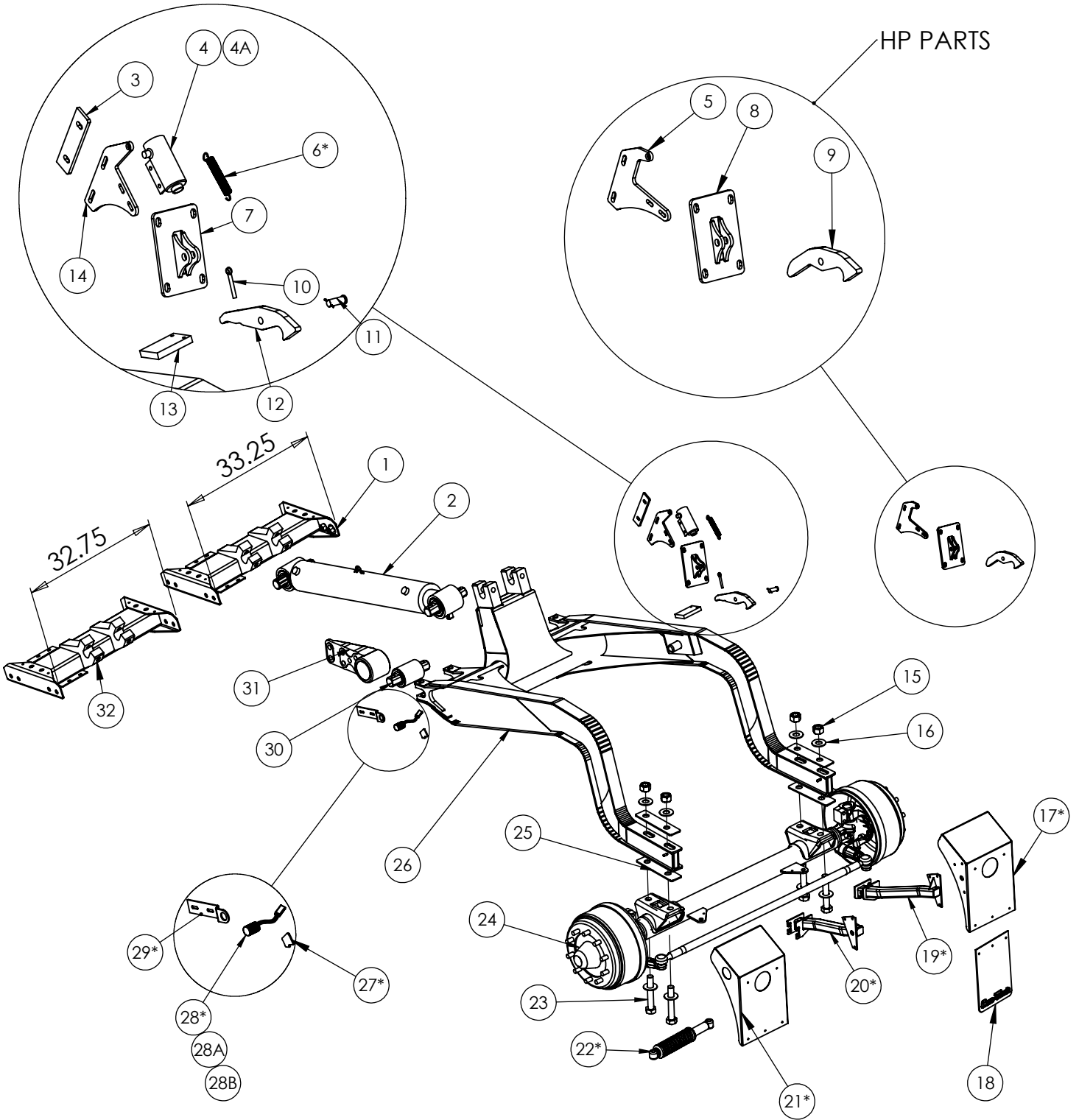

BridgeKing Trailer

***CAN BE USED ON MTM (BMV)**

ITEM #	PART #	DESCRIPTION
1	245015	CROSS MOUNT WLDT
2	750050	BRIDGEKING CYL
3	245054	SAFETY CYL- SPRING MOUNT TAB
4	750060	BRIDGEKING LATCH CYL
4A	750004	BRIDGE MASTER LATCH CYL
5	215555	HP SAFETY CYL- SPRING MOUNT
6*	705001	LATCH SPRING
7	245049	SAFETY HOOK LATCH PLATE WLDT
8	215552	HP PED HOOK PIVOT WLDT
9	215554	HP SAFETY HOOK
10	705031	EYE BOLT BK LATCH SPRING
11	705037	TRAILER HOOK PIVOT PIN
12	245050	SAFETY HOOK
13*	720050	TRAILER STOP BLOCK
14	245051	SAFETY CYL- SPRING MOUNT
15	LOCK NUT	1 1/4" LOCK NUT
16	FLAT WASHER	1 1/4" FLAT WASHER
17*	245115	ALUMINUM FENDER-BK WLDT RH
18	730040	CTM BK MUDFLAP
19*	245194	BK FENDER MNT WLDT RH HENDRICK
20*	245193	BK FENDER MNT WLDT LH HENDRICK
21*	245116	ALUMINUM FENDER-BK WLDT LH
22*	790005	ALIGNMENT SHOCK
23	BOLT	1 1/4"-12 UNC X 9" BOLT
24	791200	HENDRICKSON AXLE ASSEMBLY
25	245039	AXLE ATTACHMENT PLATE
26	245020	BRIDGEKING TRAILER
27*	245143	BK TRAILER PROX FLAG
28*	715008	PROX SWITCH
28A	715007	3 WIRE PROX W/ WEATHER PACK
28B	715125	1 WIR PROX W/ WEATHER PACK
29*	245129	TRAILER PROX MOUNT
30	750051	BRIDGEKING PIVOT BUSHING
31	245114	TRAILER PIVOT CASTING- 33 1/2"
32	245177	CROSS MOUNT WLDT NARROW MACK
NS	791202	HENDRICKSON TIE ROD END ASSEMBLY
NS*	790011	AXLE KING PIN KIT (SCREW ON CAP)
NS*	790010	AXLE KING PIN KIT (BOLT ON CAP)
NS*	720001	MTM (BMV) TRAILER PIVOT PIN
NS*	720070	MTM (BMV) TRAILER PIVOT BUSHING
NS*	791202	TIE ROD-HENDRICKSON

Cab Control Box

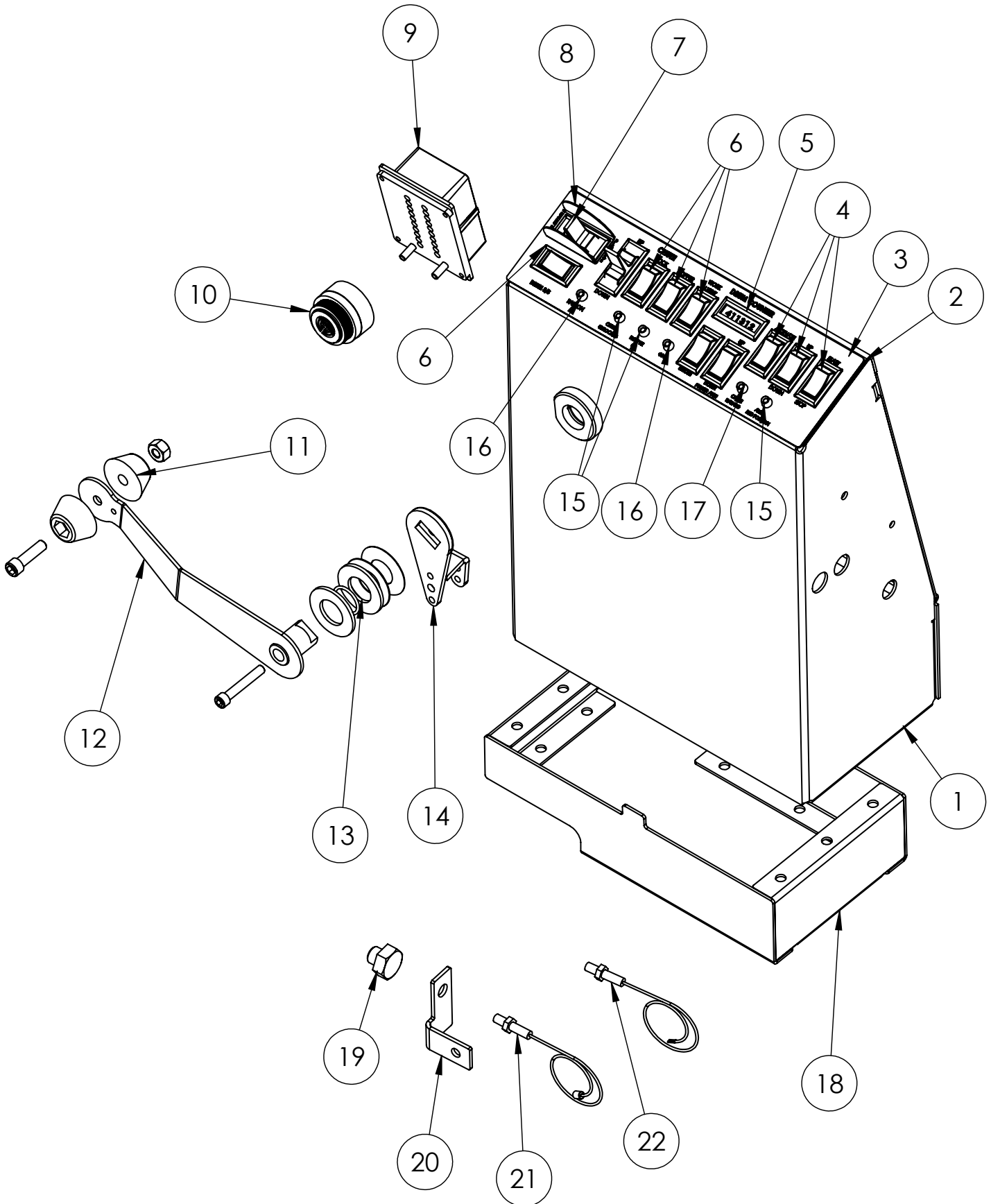

Cab Control Box

ITEM#	PART #	DESCRIPTION
1	285563	FORMED CONTROL BOX BARE
2	285192	IN CAB BOX COVER PLATE
3	799041	ELEVEN SWITCH PLACARD
4	715605	SELF CENTER ROCKER SWITCH
5	715009	DRUM COUNTER
6	715606	ON/OFF ROCKER SWITCH
7	715604	PADDLE SELF CENTER ROCKER SWITCH
8	285185	SWITCH GUARD
9	715550	FUSE BOX
10	715300	BUZZER ALARM
11	705508	RED KNOB KIT
12	705511	IN CAB CONTROL HANDLE
13	705512	CONTROL ARM WASHER KIT
14	705501	PLATE-DRUM ROTATION CONTROL LEVER
15	715136	RED LED LIGHT
16	715135	GREEN LED LIGHT
17	715137	AMBER LED LIGHT
18	285495	CAB BOX RISER
19	715018	DRUM COUNTER MAGNET
20	285040	ELECTRONIC MAG CONTROL BRACKET
21	715048	PENCIL PROX 72" W/CONNECTOR
22	715010	PENCIL PROX LONG LEAD

Rear Control Pendant

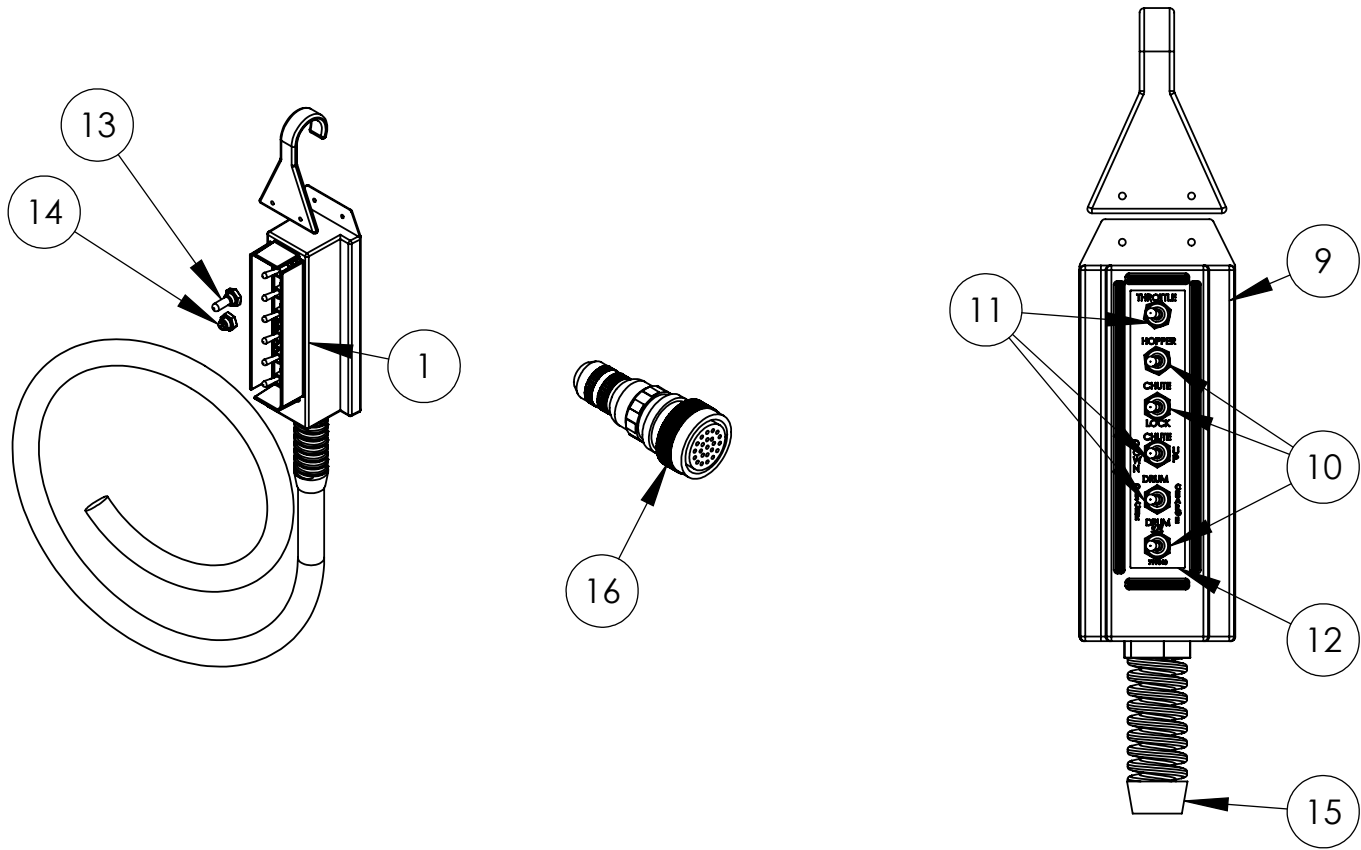

ITEM #	PART #	DESCRIPTION
1	715505	CTM REAR CNTRL PEND ASSY W/5 FT CORD
NS	715525	CTM REAR CNTRL PEND ASSY W/25 FT CORD
NS	715535	MTM REAR PEND 5' FT CORD DEUTSCH
NS	715530	MTM REAR PEND 25' FT CORD DEUTSCH
NS	715540	MTM REAR PEND 5' FT CORD W/P 1 WIRE SS
NS	715545	MTM REAR PEND 5' FT CORD W/P 3 WIRE SS
NS	715541	MTM REAR PEND 25' FT CORD W/P 1 WIRE SS
NS	715546	MTM REAR PEND 25' FT CORD W/P 3 WIRE SS
9	765006	BOX-REAR CONTROL PENDANT (BARE)
10	715133	ON\OFF TOGGLE SWITCH (SPADE TERM)
11	715132	SELF CENTER TOGGLE SWITCH (SPADE TERM)
12	799040	REAR CONTROL PENDANT PLACARD
13	730200	FULL TOGGLE SWITCH BOOT
14	730201	HALF TOGGLE SWITCH BOOT
15	710011	3/4" STRAIN RELIEVE
16	761045	DEUTSCH CONNECTOR-PENDANT SIDE
NS	765030	OMNEX KIT (WIRELESS)
NS	765031	OMNEX TRANSMITTER
NS	765032	OMNEX RECEIVER
NS	765033	OMNEX CHARGER BASE (TRANSMITTER)
NS	765034	OMNEX TRANSMITTER POUCH
NS	765007	REAR PENDANT HOOK
NS	715200	16/18 PENDANT CABLE (BY FOOT)

Rear Aluminum Control Box

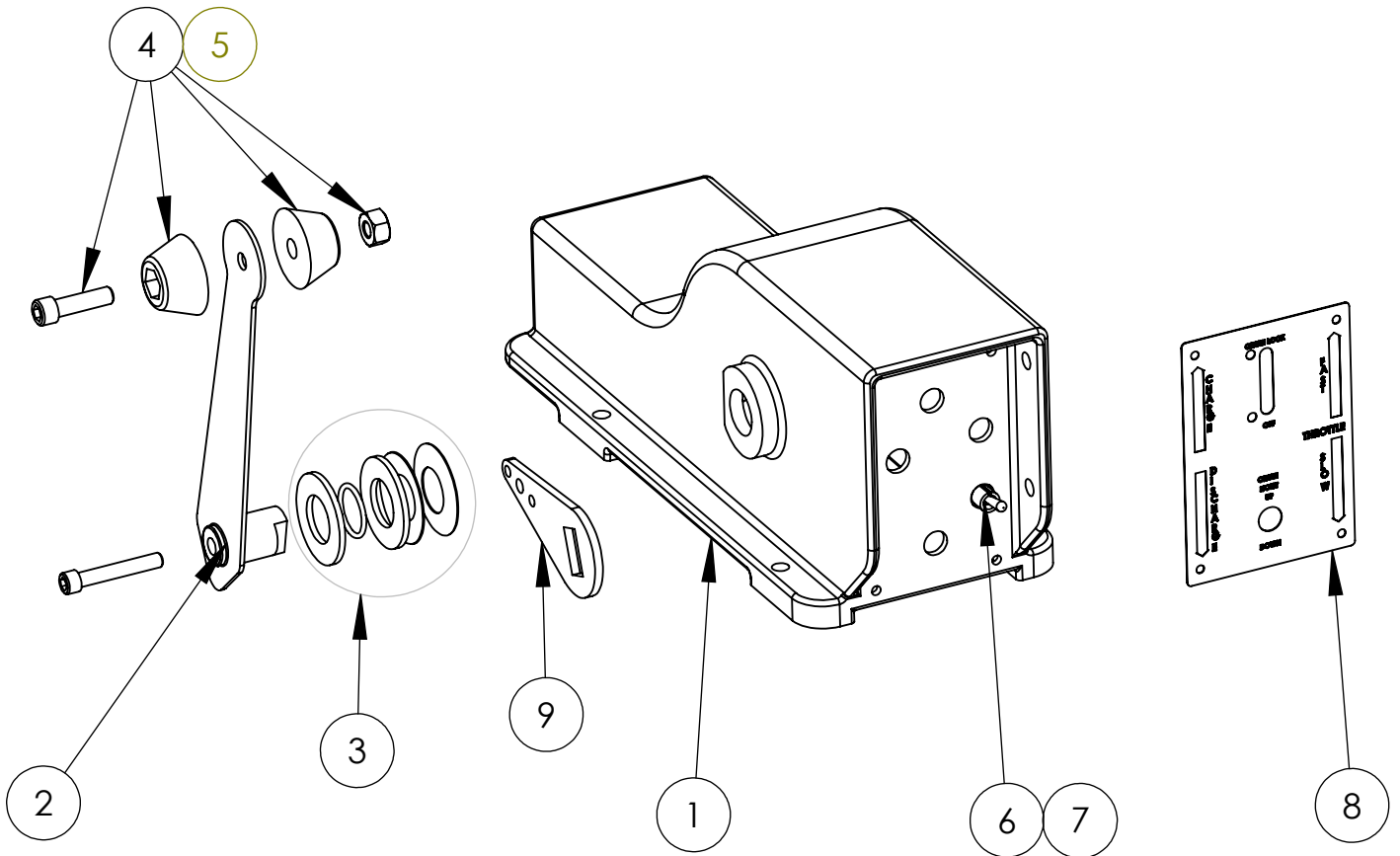

ITEM #	PART #	DESCRIPTION
1	765000	REAR CONTROL BOX
2	705500	HANDLE- CONTROL BOX
3	705512	CONTROL ARM WASHER KIT
4	705508	RED KNOB KIT
5	705509	GREEN KNOB KIT
6	715130	SEALED SELF CENTER TOGGLE SWITCH W/PIGTAILS
7	715131	SEALED ON/OFF TOGGLE W/PIGTAILS
8	PLACARD	ORDER BY APPLICATION
9	705501	BRACKET TEAR DROP
NS	765001	ONE HANDLE REAR CONTROL BOX

Control Cables and Accessories

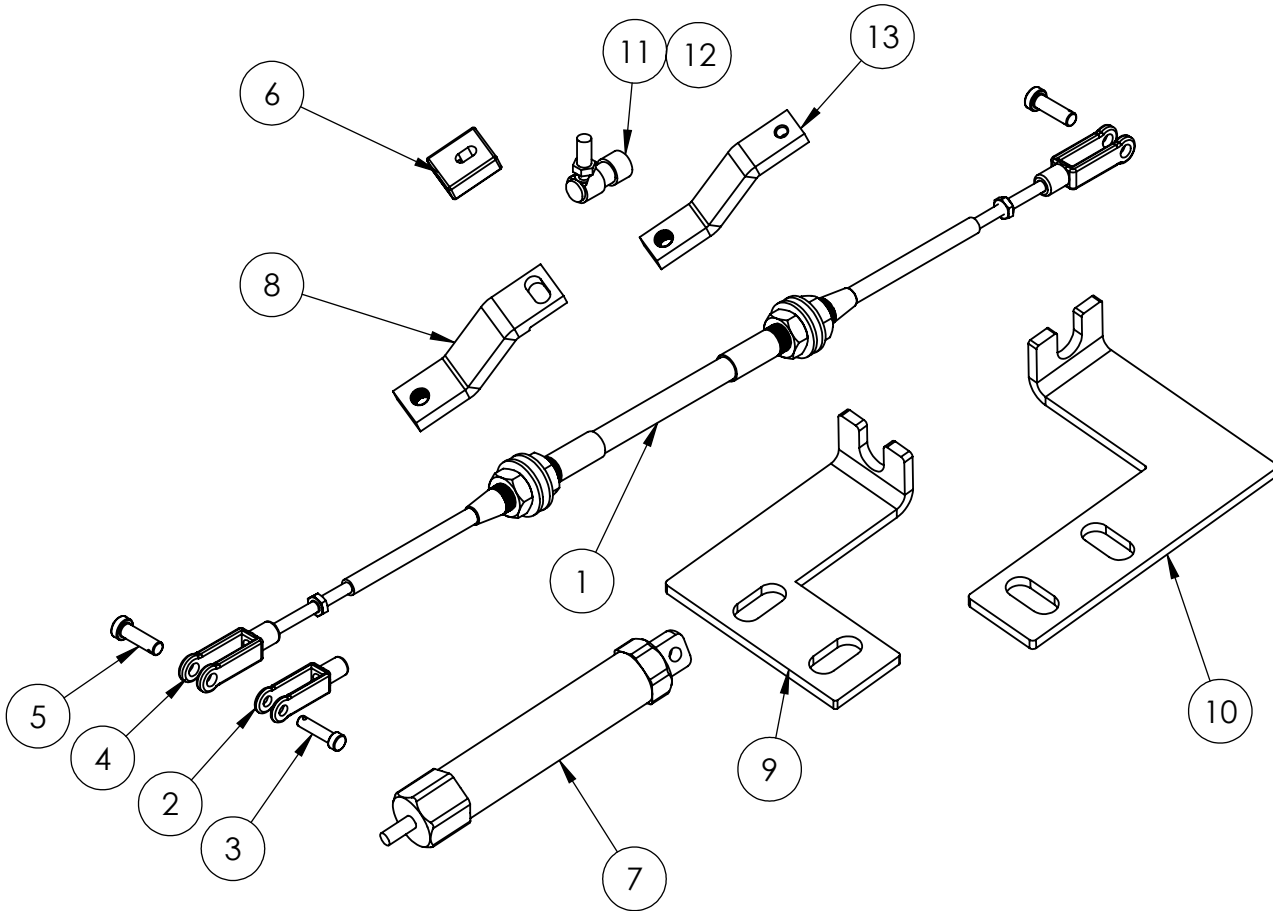

CABLE CHART

ITEM #	PART #	DESCRIPTION
1	SEE CHART	CONTROL CABLE ASSY
2	705008	1/4" CABLE CLEVIS
3	705009	1/4" CABLE CLEVIS PIN
4	705010	5/16" CABLE CLEVIS
5	705011	5/16" CABLE CLEVIS PIN
6	720060	BLOCK- CABLE SQUARE
7	750020	HYDRAULIC CONTROL CYL
8	285152	TECH FORCE PUMP CNTRL ARM
9	285145	PUMP CABLE MNT FRONT
10	285173	PUMP CABLE MNT REAR
11	705032	5/16" QUICK DISCONNECT
12	705041	1/4" QUICK DISCONNECT
13	285151	CABLE PUMP CNTRL ARM

PART #	DESCRIPTION
780048	44BB48 CONTROL CABLE
780060	44BB60 CONTROL CABLE
780084	44BB84 CONTROL CABLE
780096	44BB96 CONTROL CABLE
780144	44BB144 CONTROL CABLE
780192	44BB192 CONTROL CABLE
780216	44BB216 CONTROL CABLE
780252	44BB252 CONTROL CABLE
780264	44BB264 CONTROL CABLE
780276	44BB276 CONTROL CABLE
780288	44BB288 CONTROL CABLE
780300	44BB300 CONTROL CABLE
780360	44BB360 CONTROL CABLE
780396	44BB396 CONTROL CABLE
780020	44BP360 THROTTLE CABLE
780051	44BP396 THROTTLE CABLE

Slump Meters and Brackets

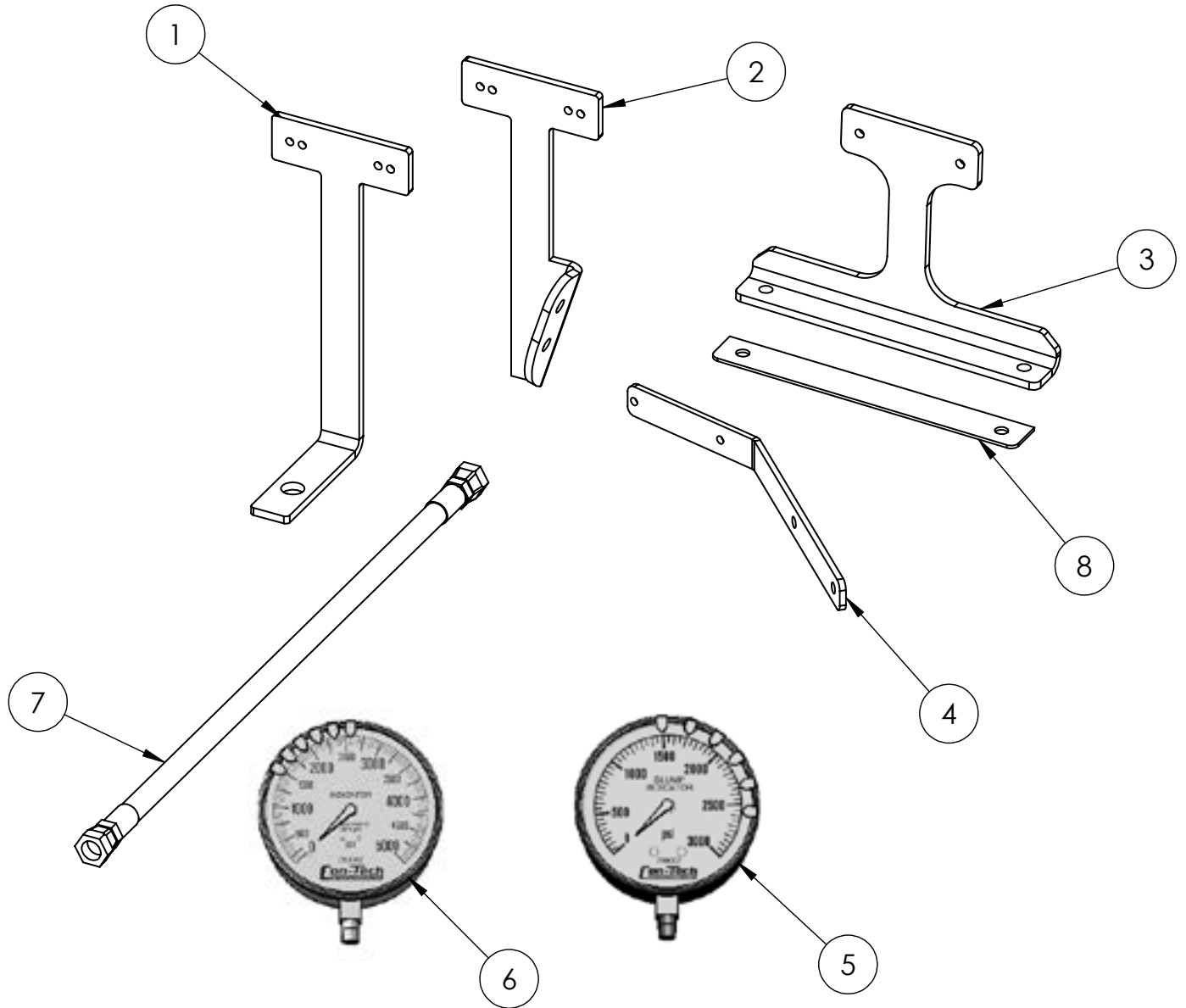

ITEM #	PART #	DESCRIPTION
1	285124	BRKT-FRNT,TRANS,T-SLUMP MOUNT
2	285123	BRKT-REAR PED, T-SLUMP MOUNT
3	285390	BRKT-FENDER,T-SLUMP MNT
4	285200	ASA COOLER SLUMP BRACKET
5	730055	GAUGE, SLUMP METER 0-3000
6	760002	GAUGE, SLUMP METER 0-5000
7	760007	36" SLUMP METER HOSE
8	730014	INSULATOR STRIP

Oil Reservoir and Mounting Brackets

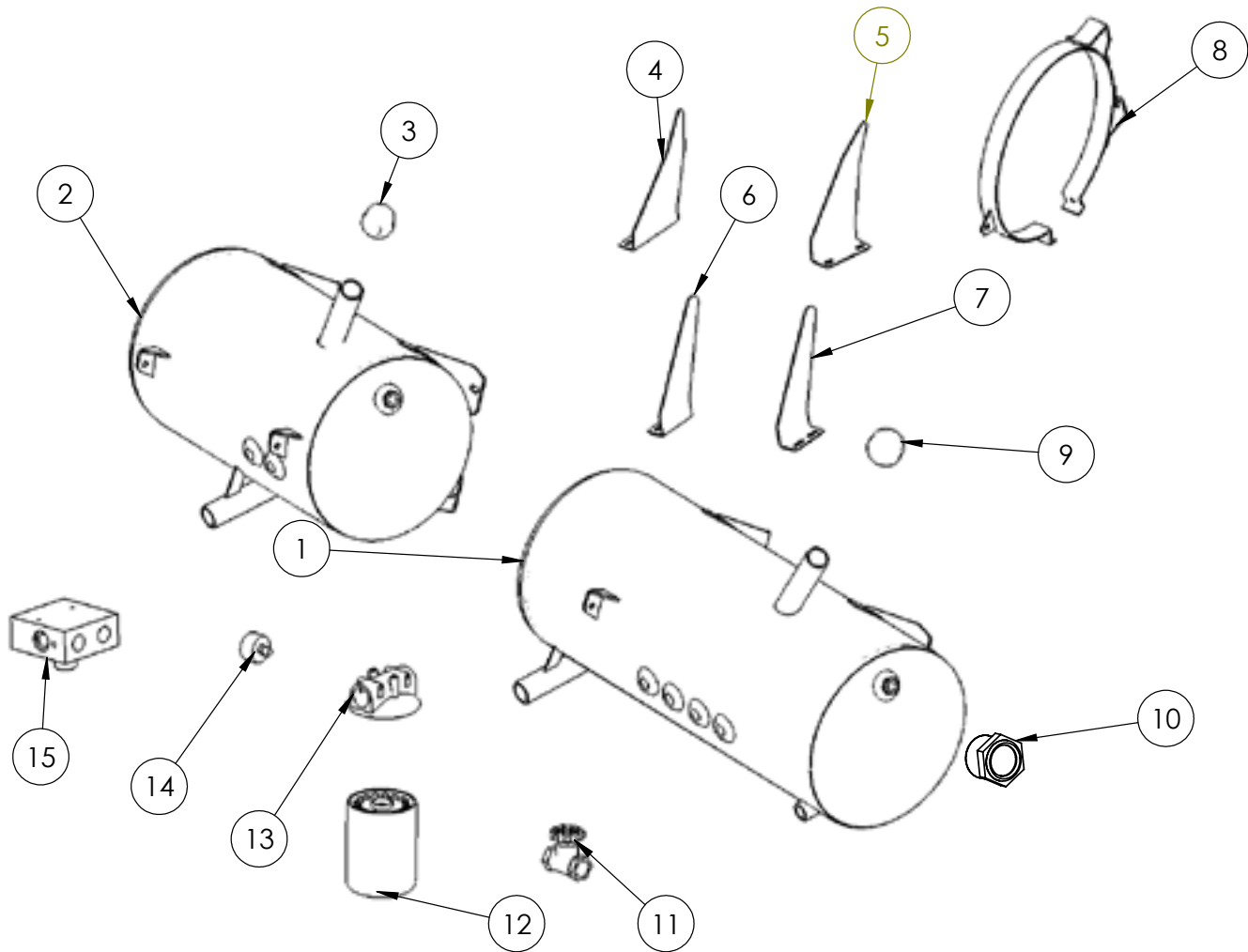

MOST PARTS ARE MTM REPLACEMENTS

ITEM #	PART #	DESCRIPTION
1	285284	18 GAL OIL RESERVIOR W/MOUNT
2	285285	13 GAL OIL RESERVIOR W/MOUNT
3	PIPE CAP	SEALED OIL RESERVOIR CAP
4	285376	BRKT-OIL FILTER MNT DUAL PORT
5	285408	BRKT-OIL FILTER MNT DUAL PORT RH
6	285109	BRKT-OIL FILTER MOUNTING LH
7	285090	BRKT-OIL FILTER MOUNTING
8	285099	OIL RESERVOIR BRKT W/TAB
9	735002	VENTED OIL RESERVOIR CAP
10	760017	OIL RESERVOIR SITE GAUGE
11	760001	1 1/4" GATE VALVE
12	735000	HYDRAULIC FILTER-SPIN ON
13	735001	OIL FILTER HOUSING
14	760001	PRESSURE GAUGE 0-100 PSI
15	735003	DUAL PORT FILTER HEAD

Water System

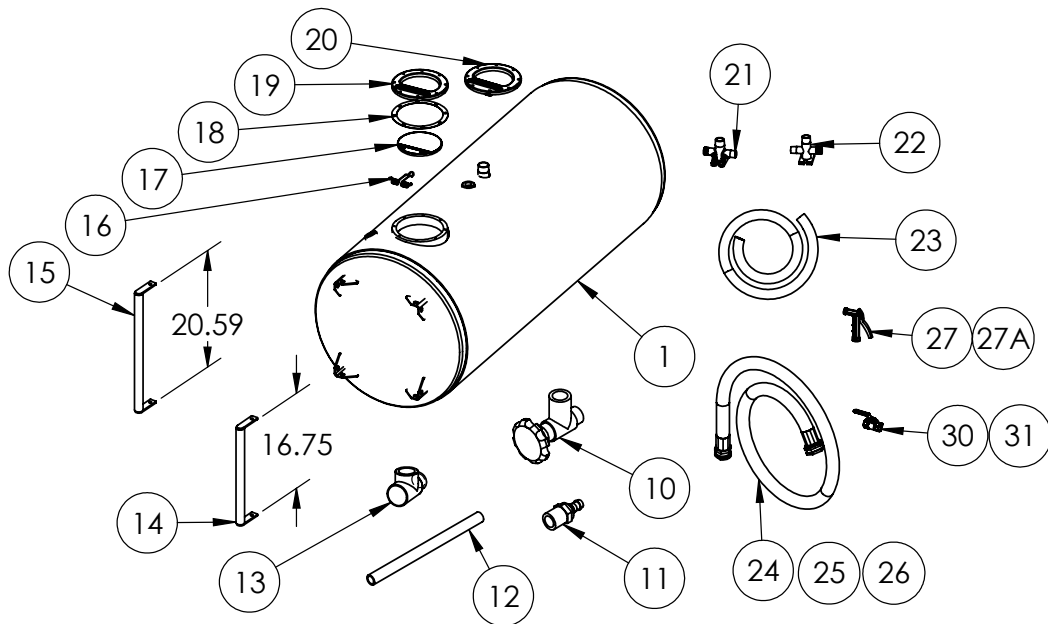

ITEM #	PART #	DESCRIPTION
1	285075	150 GAL WATER TANK-ALUMINUM
NS	285063	150 GAL WATER TANK-STEEL
NS	285074	125 GAL WATER TANK-ALUMINUM
NS	285062	125 GAL WATER TANK-STEEL
NS	285138	135/15 GAL SPLIT WATER TANK-STEEL
NS	285218	135/15 GAL SPLIT WATER TANK-ALUMINUM
NS	285064	200 GAL WATER TANK-STEEL
NS	285076	200 GAL WATER TANK-ALUMINUM
NS	285477	300 GAL WATER TANK-STEEL
10	760004	VALVE-SHUT OFF
11	710008	NIPPLE-PUSH LOCK
12	730025	HOSE-PUSH LOCK SPECIFY LENGTH
13	760030	60 PSI POPOFF VALVE
14	285084	WATER TANK HANDLE
15	285440	WLDT-WATER TANK HANDLE
16	705020	SPRING-FLOPPER 1 PIECE
17	730018	FLOPPER SEAL
18	725011	GASKET-FLOPPER
19	770001	FLOPPER TOP CASTING
20	725009	FLOPPER ASSEMBLY
21	710000	ALUMINUM WATER TEE
22	710001	STEEL WATER TEE
23	730001	1" WATER HOSE SPECIFY LENGTH
24	730070	10' WASHOUT HOSE
25	730009	25' WASHOUT HOSE
26	730071	40' WASHOUT HOSE
27	730030	WASHOUT HOSE NOZZLE
27A	730034	INSULATED SPARY NOZZLE
NS	710200	ELBOW 1 1/4" FEMALE - 1" FEMALE
NS	710009	HOSE BARB 1" NPT TO 1" BARB
30	760018	3/4 BALL VALVE
31	760003	1" BALL VALVE
NS	760008	DEAD MAN VALVE

Site Gage Brackets

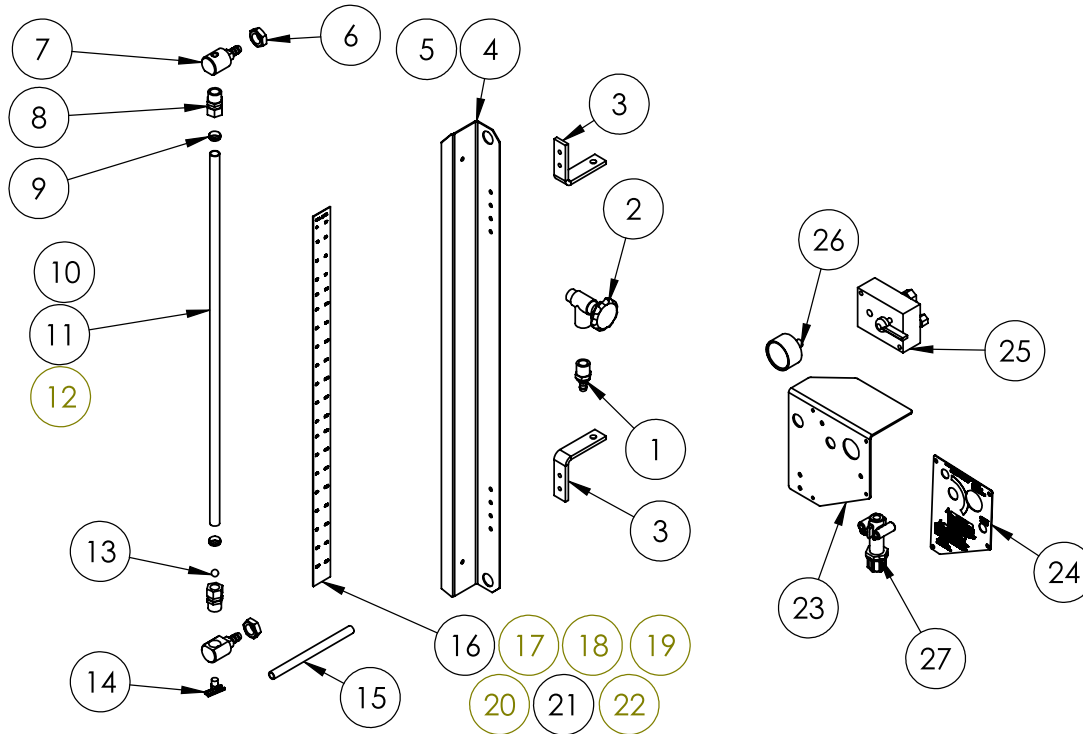

ITEM #	PART #	DESCRIPTION
1	710008	NIPPLE-PUSH LOCK
2	760004	VALVE-SHUT OFF
3	285021	WATER TANK SIGHT GAUGE MOUNT
4	285022	30" HEAD SIGHT GAUGE BRACKET
5	285038	26" HEAD SIGHT GAUGE BRACKET
6	705013	NUT-SITE GLASS
7	710002	SITE GLASS MNT
8	710010	ADAPTER-NPT TO TUBE
9	720012	SLEEVE-COMPRESSION
10	730032	36" SIGHT GLASS
11	730027	28" SIGHT GLASS
12	730028	8' SIGHT GLASS
13	730029	FLOATING BALL
14	710007	PETCOCK 1/8"
15	730025	HOSE-PUSH LOCK SPECIFY LENGTH
16	799003	90 GAL STRIP
17	799001	100 GAL STRIP
18	799002	125 GAL STRIP
19	799006	135/15 GAL STRIP
20	799004	150 GAL STRIP
21	799005	200 GAL STRIP
22	799018	300 GAL STRIP
23	285023	WATER TANK CONTROL MOUNT
24	799101	WATER TANK CONTROL MOUNT LABEL
25	760031	WATER-TANK BLOCK ASS'Y
26	760001	PRESSURE GAUGE 0-100 PSI
27	760023	HOLD BACK VALVE
1-14	760200	SITE GAUGE KIT

Water Tank Brackets

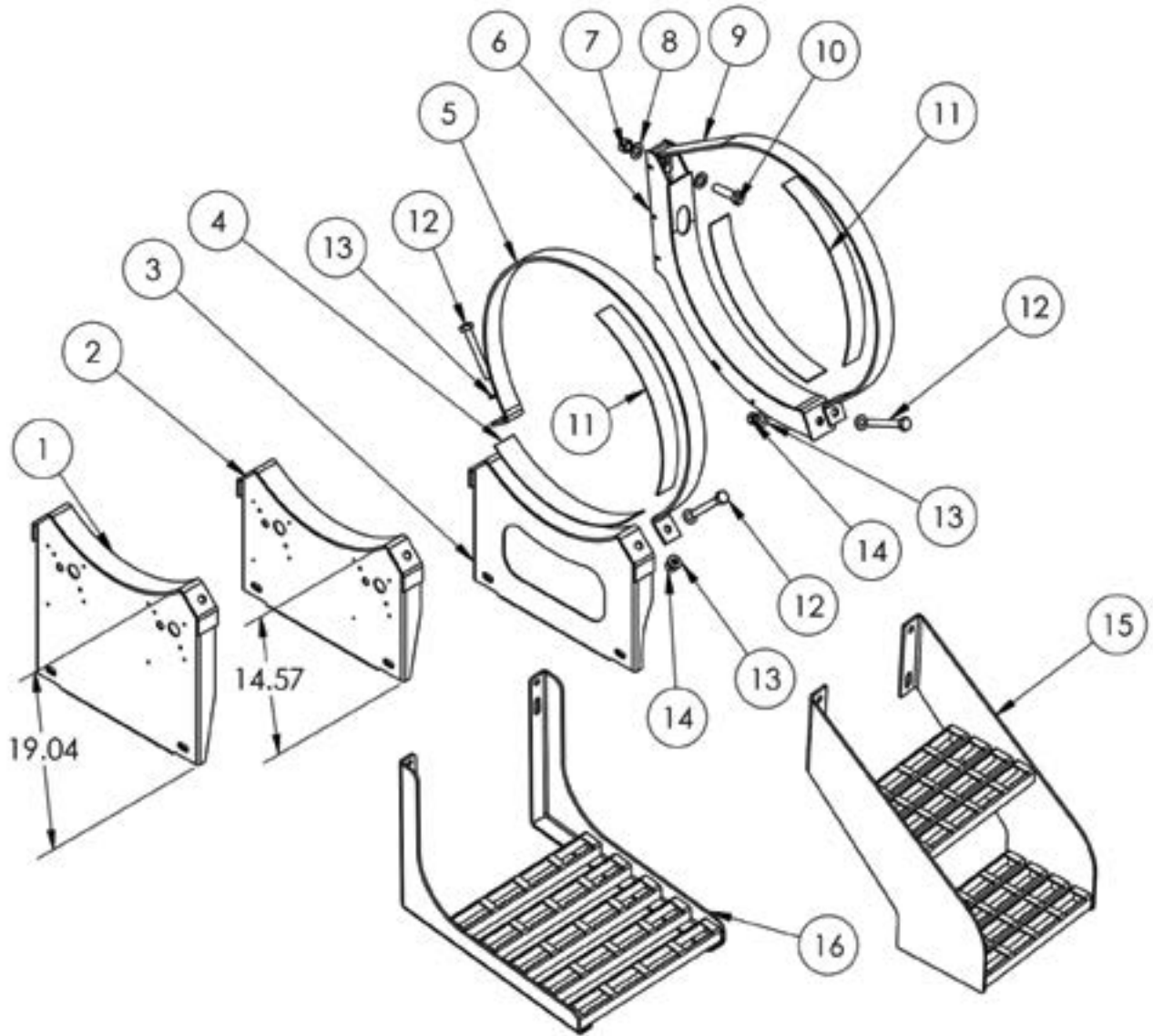

ITEM #	PART #	DESCRIPTION
1	285245	16" TALL CROSS MOUNT WATER BRACKET
2	285091	WLDT-CROSS MNT WT BRKT
3	285455	WLDT-CROSS MNT WT BRKT
4	730011	2-1/2" RUBBER STRAP
5	285308	CROSS TANK STRAP
6	285025	WATER TANK FRAME SIDE MOUNT
7	3/4" NUT	NUT, 3/4"- 10 X D-N
8	FW 0.75	WASHER, 3/4" FLAT
9	285032	WATER TANK MOUNT STRAP
10	3/4" BOLT	BOLT, 3/4"-10 X 2.75
11	730005	2" RUBBER STRAP
12	5/8" BOLT	BOLT, 5/8"-11 X 5"
13	FW 0.625	WASHER, 5/8" FLAT
14	5/8" NUT	NUT, 5/8" UNC LOCK
15	285240	WATER TANK TWO STEP
16	285447	WATER TANK STEP WLDT

Steel and Aluminum Fenders

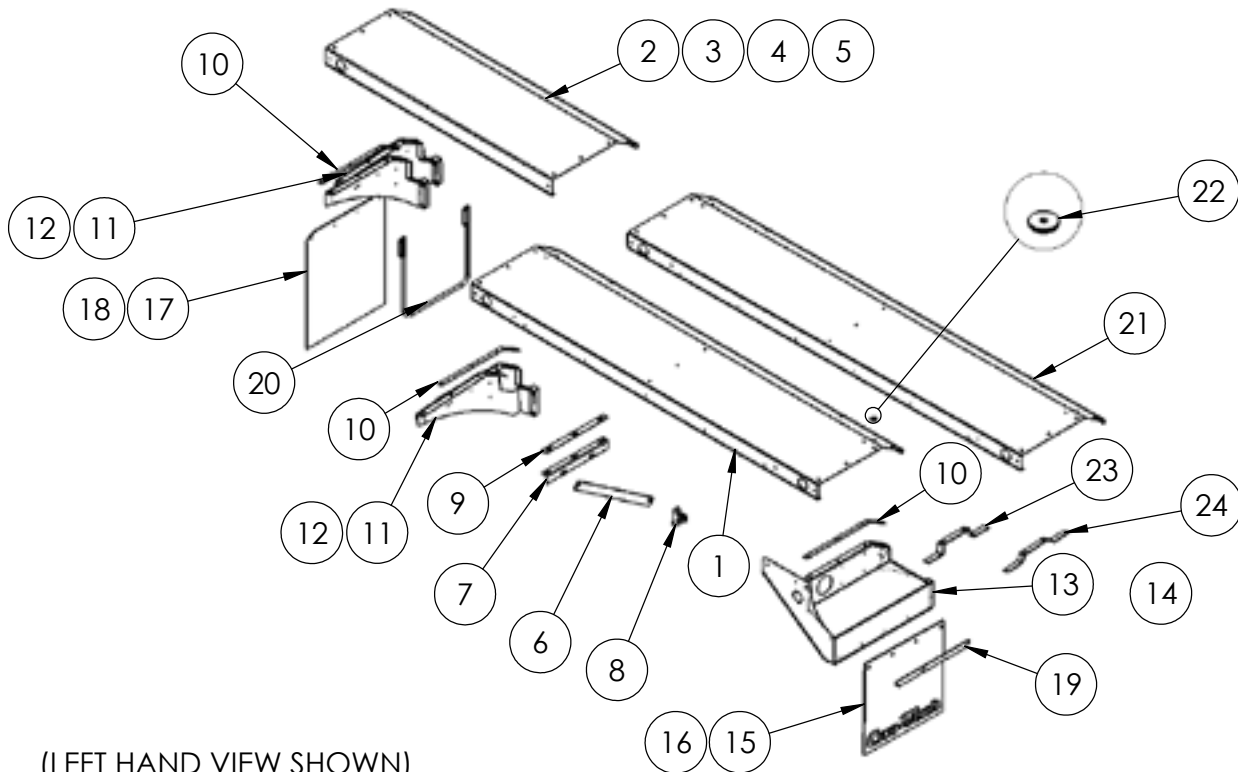

(LEFT HAND VIEW SHOWN)

PARTS LIST FOR ALUMINUM FENDERS

ITEM #	PART #	DESCRIPTION
1	205082	PSHR,FENDER,ALUM,70" LH
2	205081	PSHR,FENDER,ALUM,70" RH
3	205080	FENDER,ALUM,107"
4	205083	PSHR,FENDER,ALUM,107" RH
5	205084	PSHR,FENDER,ALUM,107" LH
6	205016	STRAP-CENTER
7	205015	BRACE-CENTER
8	205017	ANGLE-CENTER BRACE
9	730026	CENTER CUSHION
10	730014	REAR CUSHION
11	205051	SUPPORT-FRONT,ALUM,LH
12	205050	SUPPORT-FRONT,ALUM,RH
13	205055	SUPPORT-REAR,ALUM,LH
14	205043	SUPPORT-REAR,ALUM,RH
15	730041	WHITE PLASTIC MUDFLAP- 24" x 24"
16	730044	RUBBER MUDFLAP- 24" x 24"
17	730042	WHITE PLASTIC MUDFLAP- 30" X 24"
18	730045	RUBBER MUDFLAP- 30" x 24"
19	205018	STRIP-MUDFLAP BACK
20	285130	ANTI-SAIL BRACKET
21	205085	BLANK FENDER, ALUMINUM, 120"
22	705000	FENDER WASHER
23	215130	PENDANT CORD RAP FENDER MNT
24	215053	PENDANT CORD HOLDER
NS	790200	FENDER FILL (PUCK BOARDS)

PARTS LIST FOR STEEL FENDERS

ITEM #	PART #	DESCRIPTION
1	205001	FENDER,STEEL,107"
2	205060	PSHR,FENDER,STEEL,70" LH
3	205061	PSHR,FENDER,STEEL,70" RH
4	205091	PSHR,FENDER,STEEL,107" RH
5	205092	PSHR,FENDER,STEEL,107" LH
6	205016	STRAP-CENTER
7	205015	BRACE-CENTER
8	205017	ANGLE-CENTER BRACE
9	730026	CENTER CUSHION
10	730014	REAR CUSHION
11	205014	SUPPORT-FRONT,STEEL,LH
12	205013	SUPPORT-FRONT,STEEL,RH
13	205003	SUPPORT-REAR,STEEL,LH
14	205002	SUPPORT-REAR,STEEL,RH
15	730041	WHITE PLASTIC MUDFLAP- 24" x 24"
16	730044	RUBBER MUDFLAP- 24" x 24"
17	730042	WHITE PLASTIC MUDFLAP- 30" X 24"
18	730045	RUBBER MUDFLAP- 30" x 24"
19	205018	STRIP-MUDFLAP BACK
20	285130	ANTI-SAIL BRACKET
21	205095	BLANK FENDER, STEEL, 120"
22	705000	FENDER WASHER
23	215130	PENDANT CORD RAP FENDER MNT
24	215053	PENDANT CORD HOLDER
NS	790200	FENDER FILL (PUCK BOARDS)

Aluminum Front Fenders

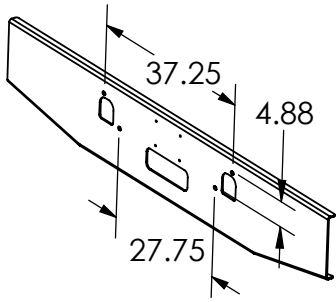

PART #	DESCRIPTION
285259	MACK GRANITE

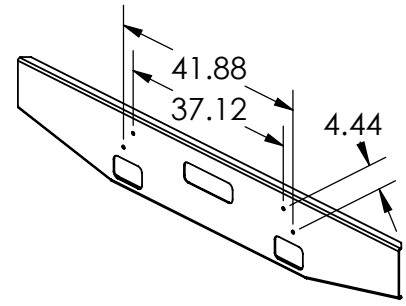

PART #	DESCRIPTION
285002	RD MACK BUMPER

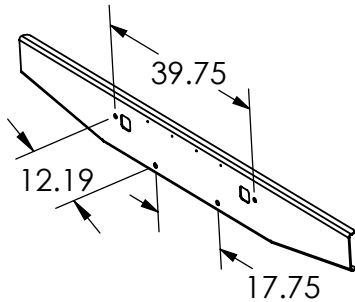

PART #	DESCRIPTION
285260	365 PETE BUMPER

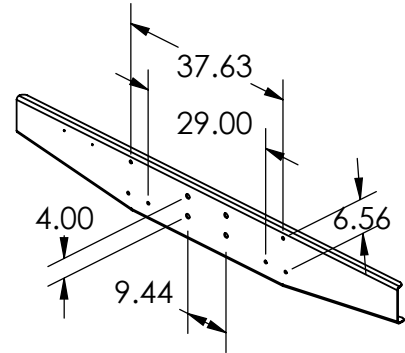

PART #	DESCRIPTION
285033	PETE BUMPER

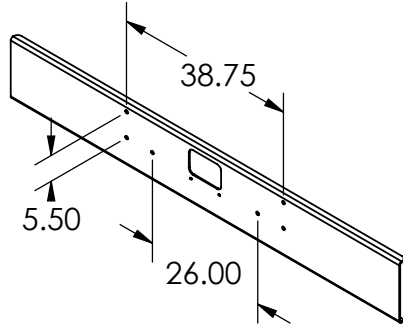

PART #	DESCRIPTION
285036	IH 5000 BUMPER

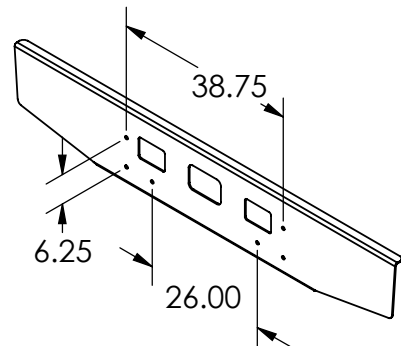

PART #	DESCRIPTION
285037	IH 5500 BUMPER

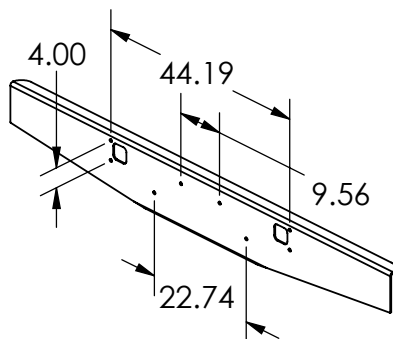

PART #	DESCRIPTION
285001	K-W BUMPER

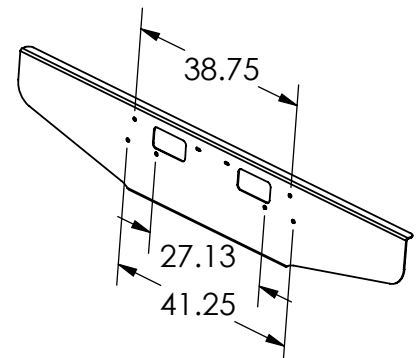

PART #	DESCRIPTION
285140	STERLING BUMPER

Rear Bumpers

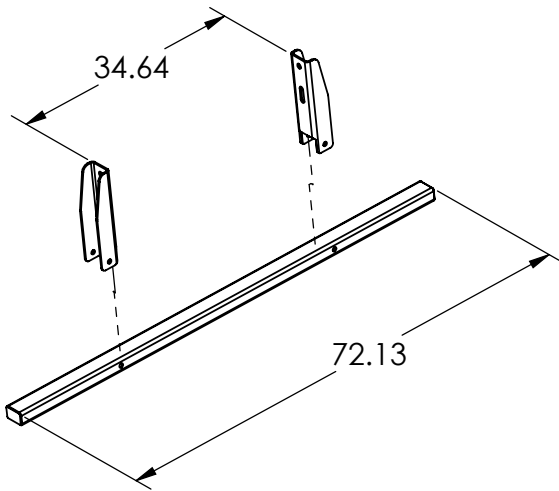

PART #	DESCRIPTION
285257	STD REAR BUMPER
285255	BRACKET

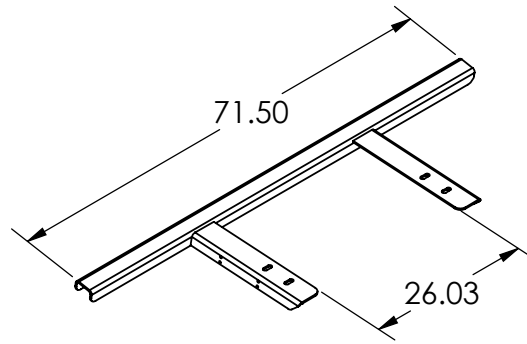

PART #	DESCRIPTION
245206	BRIDGE KING REAR BUMPER
285014	MOUNT BK BUMP LIGHT

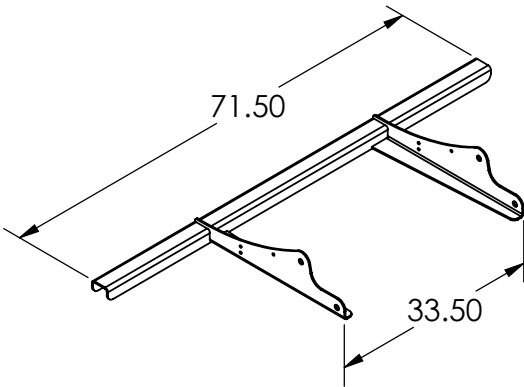

PART #	DESCRIPTION
285015	MTM BMV REAR BUMPER

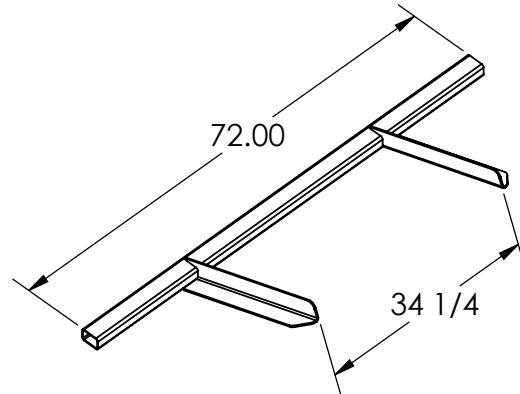

PART #	DESCRIPTION
285010	MTM BMIII REAR BUMPER

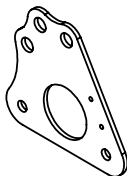

PART #	DESCRIPTION
285013	MTM BMV REAR BUMPER FRAME MOUNT

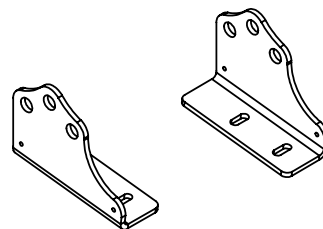

PART #	DESCRIPTION
245127 RH	BK BUMPER MNTG BRKTS
245128 LH	

Drum Parts

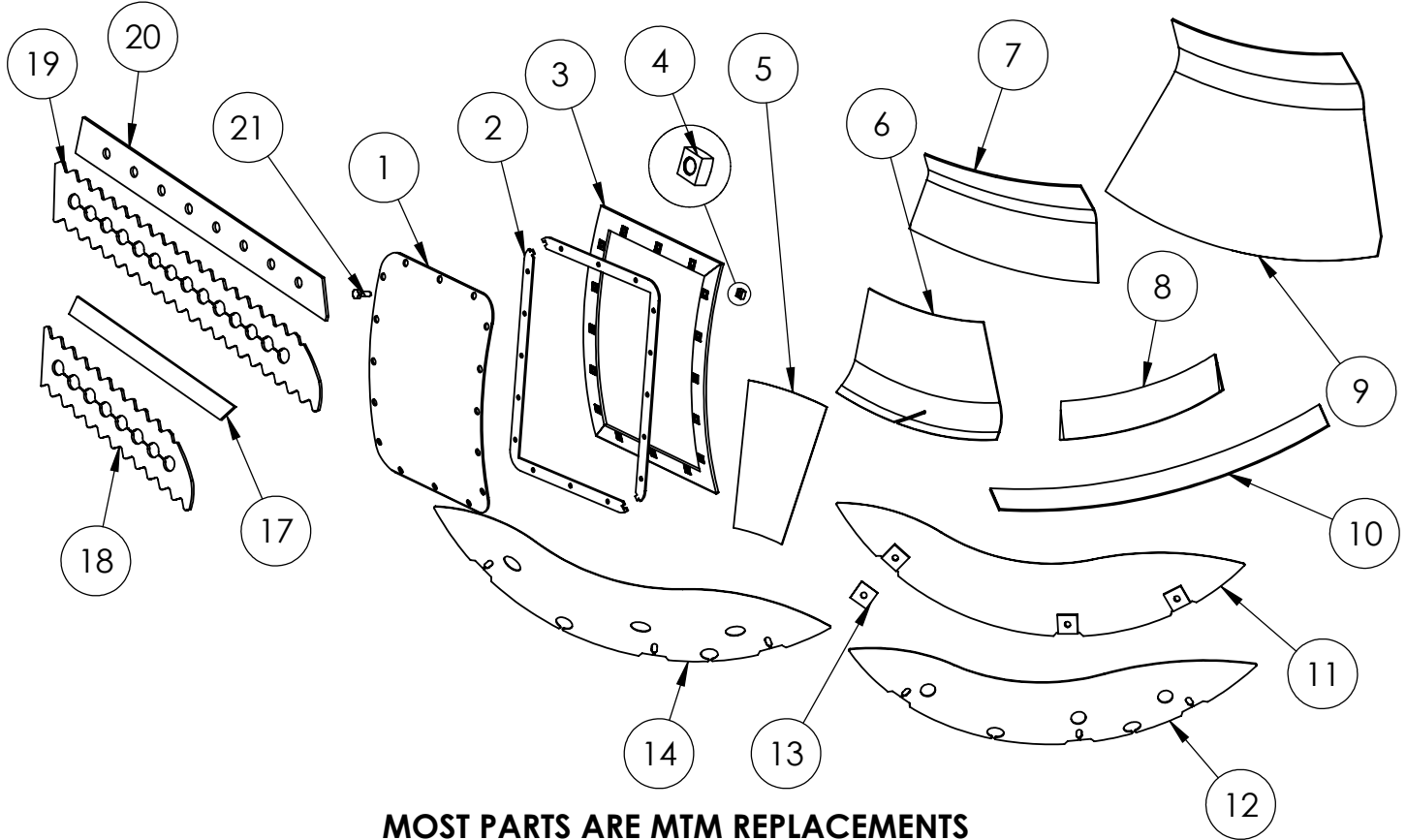

MOST PARTS ARE MTM REPLACEMENTS

ITEM #	PART #	DESCRIPTION
1	255004	HATCH COVER
2	725006	2 PC SQUARE HATCH GASKET
3	255003	HATCH FRAME WLDT
4	705008	1/2"-13 HD SQUARE NUT
5	255244	HP HEAD LINER
6	255053	HEAD INSIDE LINER
7	255033	FIN CAP 3/16"
8	255054	HEAD RADIUS LINER
9	255138	UNIVERSAL FIN
10	255035	BELLY LINER
11	255044	SURGE BLADE 3 TAB
12	255134	CTM STD SURGE BLADE
13	255046	SURGE BLADE TAB
14	255135	CTM PVR SURGE BLADE
15	255136	CTM STD SURGE BLADE ASSY
16	255137	CTM PVR SURGE BLADE ASSY
17	255201	BALL BUSTER SHORT GUSSET
18	255202	BALL BUSTER SHORT BLADE
19	255200	BALL BUSTER LONG BLADE
20	255199	BALL BUSTER LONG GUSSET
21	705015	1/2" X 1 1/2" UNC BOLT
NS	255171	9 YD FIN KIT
NS	255172	9 1/2 -10 YD FIN KIT
NS	255173	10.5 YD FIN KIT
NS	255174	11 YD FIN KIT

Lights, Wiring, Harnesses, and Accessories

LIGHTING

ITEM #	PART #	DESCRIPTION
1	715023	LIGHT, 2.5" RED LED
2	715024	LIGHT, 2.5" AMBER LED
3	715022	LIGHT 4" STOP, TAIL TURN LED
4	715002	GROMMET 2.5"
5	715004	GROMMET 4"
6	715030	RED REFLECTORS (SCREW ON)
7	715031	AMBER REFLECTORS (SCREW ON)
8	715032	RED REFLECTORS (ADHESIVE)
9	715033	AMBER REFLECTORS (ADHESIVE)
10	715020	PIGTAILS- 2 WIRE
11	715021	PIGTAILS- 3 WIRE
12	715025	WORK LIGHTS INCANDESCENT, ROUND 4
13	715045	4" ROUND LED WORK LIGHT
14	715028	STROBE LIGHTS 4" POP IN GROTE
15	715029	PIGTAIL- GROTE
16	715046	BACK UP LIGHTS-4" LED
17	715400	ECCO BACK UP ALARM
18	715405	PRECO BACK UP ALARM
19	715034	DOT TAPE
20	215327	SINGLE TAIL LIGHT BOX
21	215347	DOUBLE TAIL LIGHT BOX

HARNESSES

ITEM #	PART #	DESCRIPTION
1	715108A	OMNEX WIRELESS CAB HARNESS
2	715111	HOPPER TRI-BAR
3	715112	STOP (TURN/TAIL HARNESS)(TANDEM FENDER)
4	715113	FENDER FRONT HARNESS (SIDE MARKER)
5	715114B	BRAKE "SPIDER" HARNESS
6	715115	BRIDGEKING HARNESS
7	715116	BK TRAILER MAIN HARNESS
8	715117	BK FENDER STOP/TURN/TAIL
9	715119	REAR BUMPER TAIL LAMP HARNESS
10	715122	STANDARD HARNESS
11	715123	CONSTANT SPEED, CAB HARNESS

DECALS AND PLACARDS

ITEM #	PART #	DESCRIPTION
1	799300	BRIDGEKING KIT
2	799200	EXTREME DUTY STD KIT
3	799700	FRENCH & ENGLISH STD KIT
4	799701	BK FRENCH

General Accessories

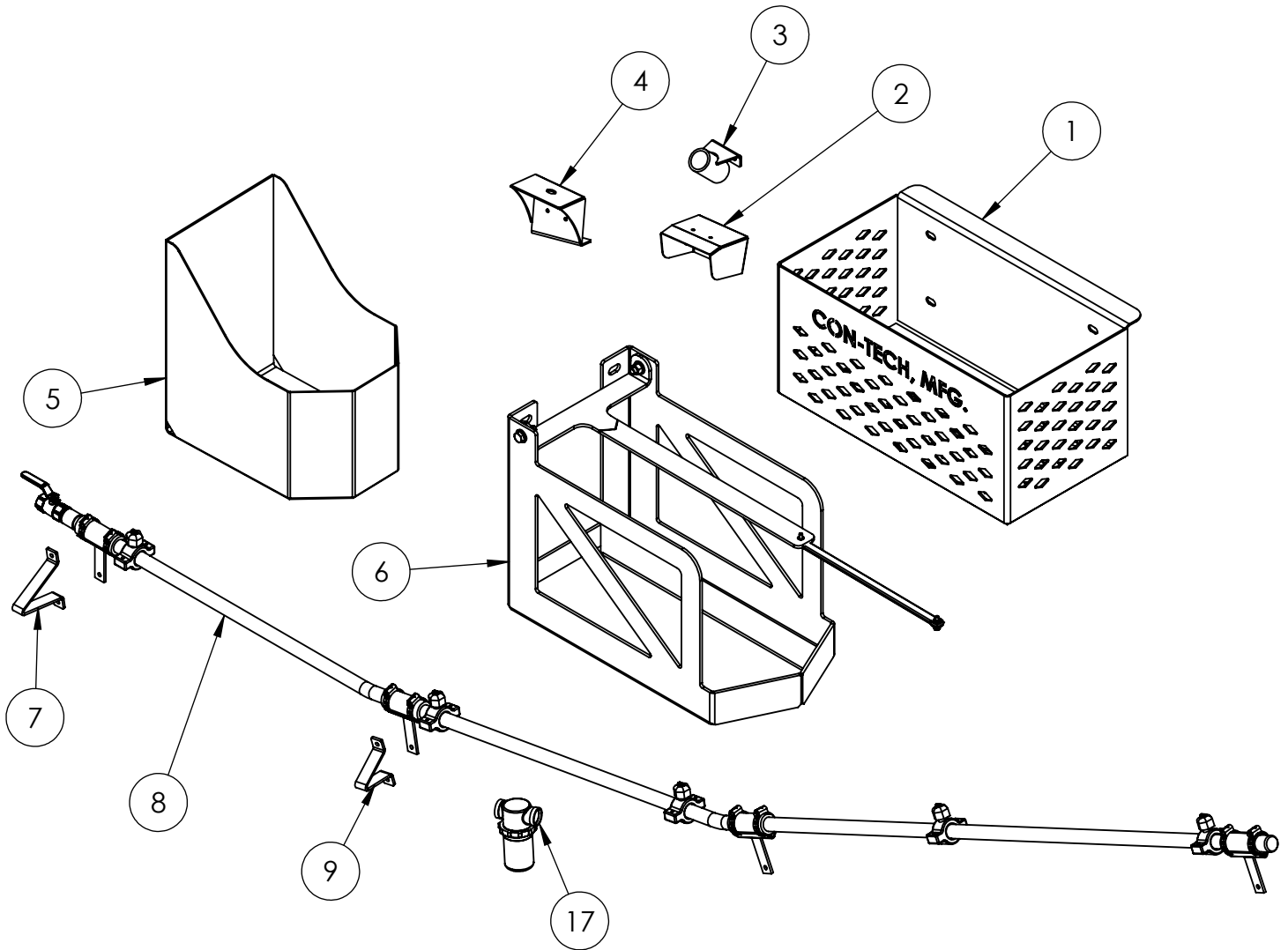

ITEM NO.	PART NUMBER	DESCRIPTION
1	285269	CHAIN BOX BASE WLDT
2	285494	REAR VIEW CAMERA ASSEMBLY
3	285400	SCRAPPER MOUNT ASSY
4	215463	LADDER CAMER MOUNT WLDT
5	285425	PAIL RACK WLDT
6	225120	PAIL BASKET ASSY
7	285437	DRUM SPRAYER MOUNT LONG
8	730007	BAR-DRUM SPRAYER ASSY
9	285438	DRUM SPRAYER MOUNT SHORT
NS	215463	LADDER CAMERA BRACKET
NS	710250	WATERTANK PUMP ELECTIC
NS	710260	WATERTANK PUMP AIR
NS	710260	WATERTANK PUMP AIR
NS	765208	ELECTRIC ADD WATER VALVE
15	730000	SPRAY BAR STRAINER

Chute Washout Systems



Washout Watch Dog System
(Poly Tank - No Pump)
Part # **799820**



Chute Wash Recovery System
(Steel Washout Box)
Part # **799830**



Enviroguard System
(Stainless w/o Chute, w/ Pump)
Part # **730300**

HP Replacement Drum Order Form

Part # _____

HP DRUM

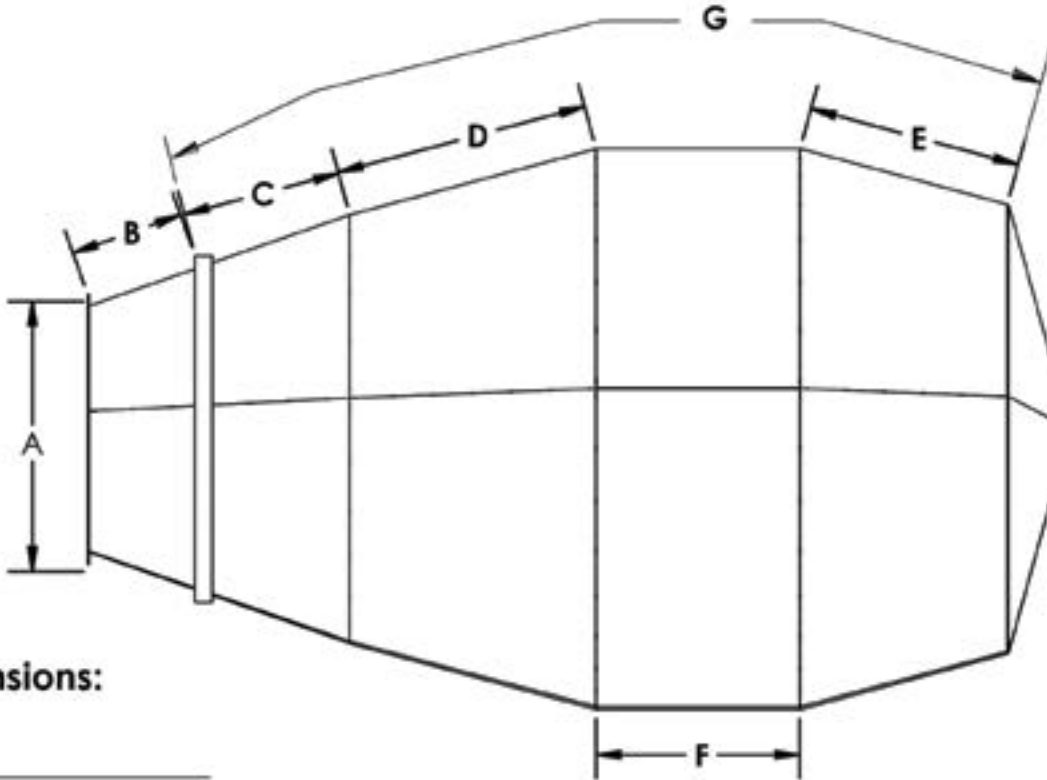

Dimensions:

- A _____
- B _____
- C _____
- D _____
- E _____
- F _____
- G _____

OPTIONS

Fin thickness desired:

- 3/16" Std. 1/4" Optional

Drum shell thickness desired:

- 3/16" Std. 1/4" Optional

Finish:

- Prime Paint

- . Sales Person _____
- . Mixer Size _____
- . Unit No. _____
- . Customer Name _____
- . Street Address _____ City _____
- . State, Zip _____ Phone _____
- . Contact _____

**CALL 507-374-2239 OR FAX 507-374-2548
FOR YOUR REPLACEMENT DRUM NEEDS.**

Replacement Drum Order Form

Part # _____

OLD CTM OR MTM STYLE DRUM

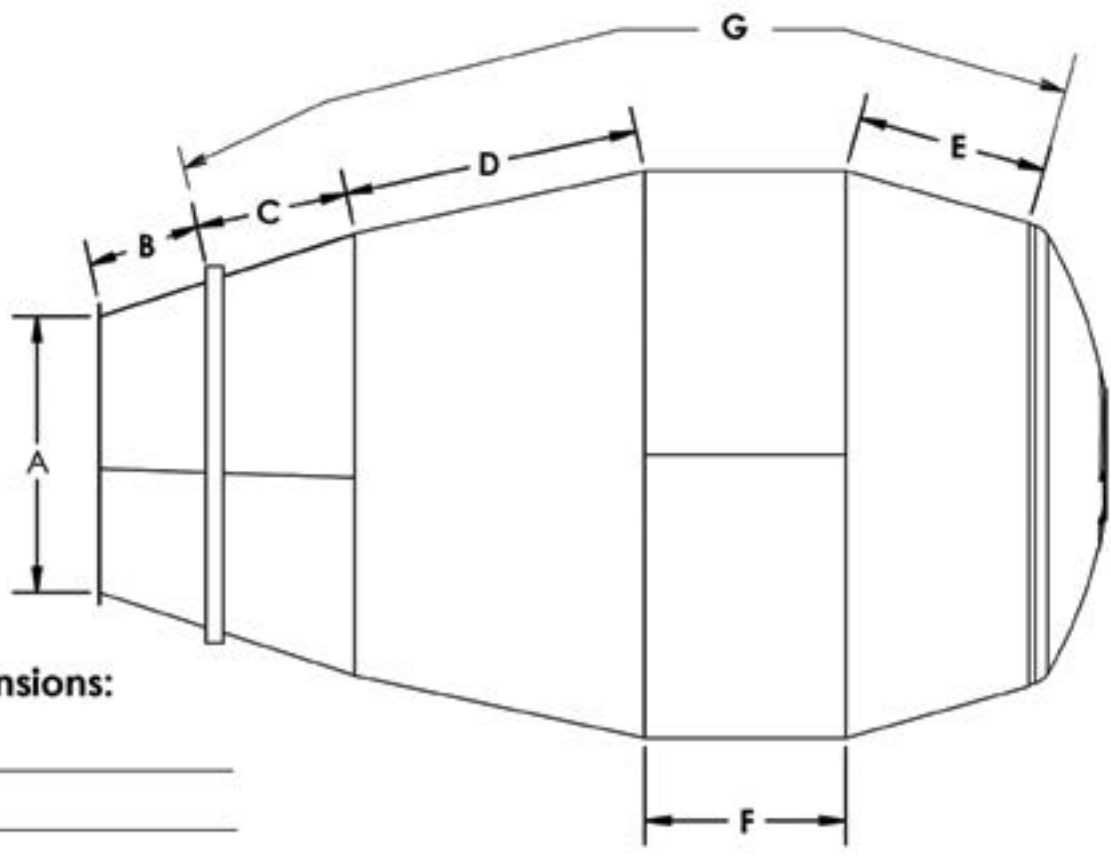

Dimensions:

- A _____
- B _____
- C _____
- D _____
- E _____
- F _____
- G _____

OPTIONS

- Fin thickness desired:
 3/16" Std. 1/4" Optional
- Drum shell thickness desired:
 3/16" Std. 1/4" Optional
- Finish:
 Prime Paint

- . Sales Person _____
- . Mixer Size _____
- . Unit No. _____
- . Customer Name _____
- . Street Address _____ City _____
- . State, Zip _____ Phone _____
- . Contact _____

**CALL 507-374-2239 OR FAX 507-374-2548
FOR YOUR REPLACEMENT DRUM NEEDS.**

Hopper Replacement Order Form

Part # _____

LUG STYLES



STD



DROP

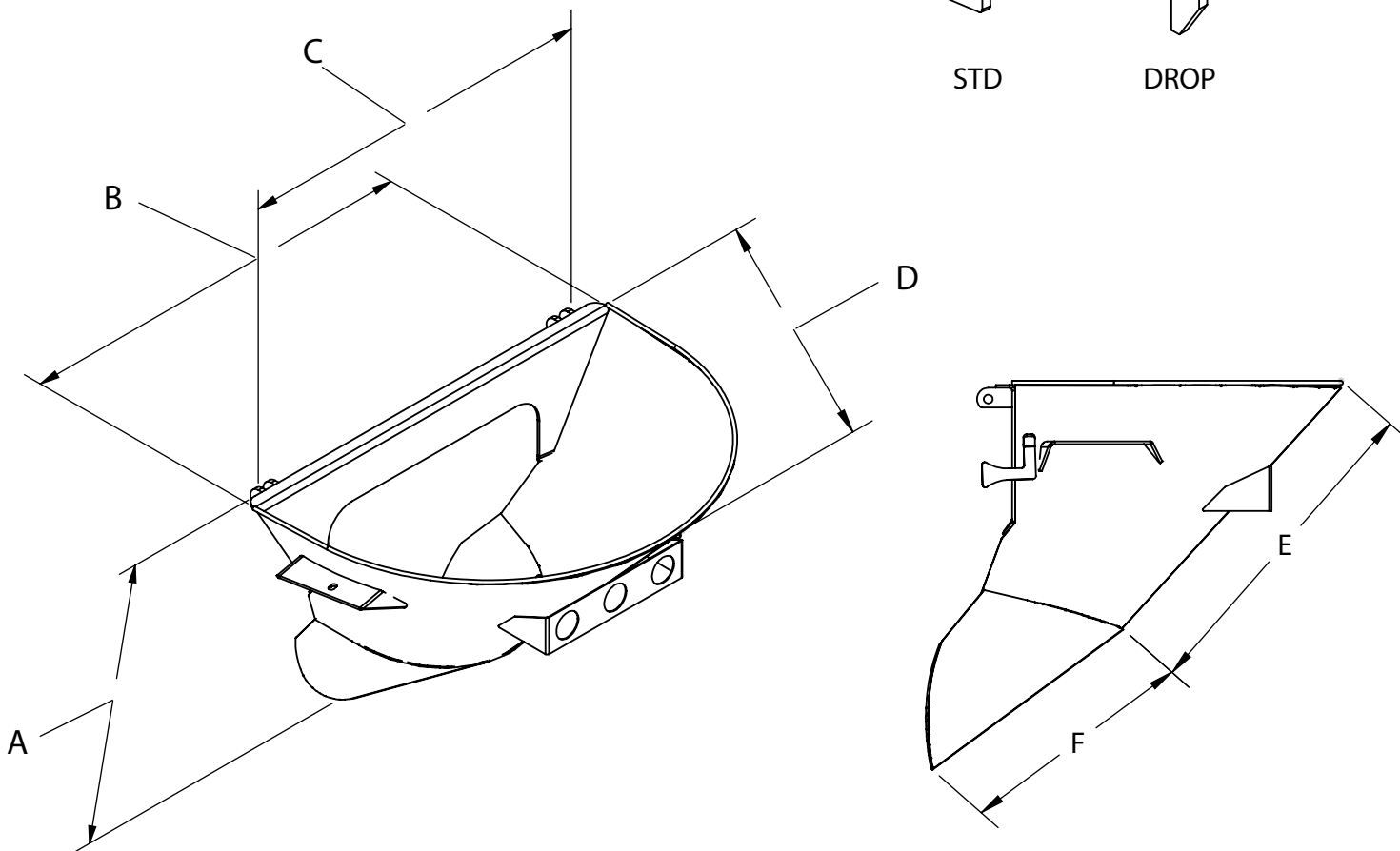

Dimensions:

A _____

B _____

C _____

D _____

E _____

F _____

. Sales Person _____

. Unit Number _____

. Customer Name _____

. Street Address _____ City _____

. State, Zip _____ Phone _____

. Contact _____

CALL 507-374-2239 OR FAX 507-374-2548
FOR YOUR REPLACEMENT HOPPER NEEDS.

Part Number Cross Reference

MTM#	CTM#	DESCRIPTION OF PART	PAGE#
1105171	775011	AXLE CYLINDER PIVOT PIN 7-5/16"	24-25
1109057	215035	UPPER LADDER BMV WLDT	14
1109058	215028	LOWER LADDER PLATFORM BMV WLDT	14
1109059	215039	LOWER LADDER BMV WLDT	14
1138155	760055	MAC VALVE REGULATOR	16
0121415	735006	COALESCING FILTER ELEMENT	16
0000008	705008	1/4" CABLE CLEVIS	30
0000076	795003	1350 U-JOINT	20-21
0000245	705036	WASHER-CHUTE LOCK	10-11
0000246	705034	CHUTE LOCK SPRING	10-11
0000247	705035	ROLL PIN 5/32" X 1-1/2"	10-11
0000248	770009	CHUTE LOCK CAST HANDLE	10-11
0000249	770008	CHUTE LOCK CAST BODY	10-11
0000259	770003	MANUAL CHUTE LOCK ASSEMBLY	10-11
0000436	735000	HYDRAULIC FILTER	20-21
0000504	760007	GAUGE, SLUMP METER 0-3000	31
0000572	799001	90 GALLON STRIP	34
0000599	799000	65 GALLON STRIP	34
0000801	705009	1/4" CABLE CLEVIS PIN	30
0000833	705010	5/16" CABLE CLEVIS	30
0000834	705011	5/16" CABLE CLEVIS PIN	30
0001280	745005	PK REMANUFACTURED	17
0001291	745003	P REMANUFACTURED	17
0002016	710007	PETCOCK 1/8"	34
0002465	725001	INPUT/OUTPUT SHAFT SEAL KIT-MECHANICAL	20-21
0002468	725002	STANDARD CONTROL VALVE-GASKET KIT	20-21
0002469	725024	CONTROL VALVE ASSEMBLY (NEW)	20-21
0002469	725024	MANUAL CONTROL VALVE SHAFT	20-21
0002481	725021	PARKER PUMP O-RING	20-21
0004351	735001	OIL FILTER HOUSING	32
0010057	705000	RUBBER BACKED FENDER WASHER	36
0010812	760402	MTM COMBO BLOCK	22-23
0010855	735010	PARKER HIGH PRESSURE FILTER ASSEMBLY	20-21
0015044	755000	3-7/8" COMPLETE DRUM ROLLER ASSEMBLY	12
0015083	725009	FLOPPER ASSEMBLY	33
0015177	285062	125 GAL WATER TANK WLDT-STEEL	33
0015337	215070	CHARGE HOPPER OLD STYLE	7
0015388	765000	REAR CONTROL BOX	29
0015513	215191	PAVER CHARGE HOPPER	7
0015514	215277	STANDARD CHARGE HOPPER V	7
0015802	780048	44BB48 CONTROL CABLE	30
0016092	720008	BEARING SPHERICAL 2-1/4"	19
0016552	705509	GREEN KNOB KIT	29
0016553	705508	RED KNOB KIT	29
0016553	705508	RED KNOB KIT	26-27
0016977	715133	ON/OFF TOGGLE SWITCH	28-29
0018186	285048	BM OIL RESERVOIR	32
0018241	215003	LADDER-LOWER PLATFORM WLDT	14
0018262	285103	OIL RESERVOIR BRKT, WLDT	32
0018284	285084	WATER TANK HANDLE WLDT	33
0021525	725013	SEAL, OIL (DEVRIES #30004499-468SAX-C2)	12
0021583	780050	44BP360 THROTTLE CABLE	30
0050042	285023	WATER TANK CONTROL MOUNT	34
0050043	215047	PENDANT HOLDER WLDT	14
0082023	760017	OIL TANK SITE GAUGE	32
0082109	710000	ALUMINUM WATER TEE	33
0082191	255053	HEAD INSIDE LINER	39
0082194	255054	HEAD RADIUS LINER	39
0082206	705005	WASHER, LOCK #10	12
0082208	710003	FITTING, 1/8" NPT GREASE	12

Part Number Cross Reference

MTM#	CTM#	DESCRIPTION OF PART	PAGE#
0082213	720003	ROLLER BEARING CONE	12
0082214	720004	CUP, ROLLER BEARING (TIMKIN 455)	12
0082216	705003	NUT, LOCK #10 (N-10)	12
0082218	720009	SHIM-ROLLER 0.036"	12
0082279	215110	MAIN PIVOT WASHER	10-11
82315	225051	CHUTE-PAVER EXTENSION WLDT	4
0082320 / 1146581	225049	CHUTE-PAVER FOLD OVER WLDT	4
0082368	285024	FENDER CHUTE RACK	5
0082369	285129	BRKT-CHUTE MOUNT	5
0082378	285025	WATER TANK MOUNT WLDT	35
0082386	730027	3' SITE GLASS	34
0082392	799004	150 GALLON STRIP	34
0082396	799002	100 GALLON STRIP	34
0082406	760022	0-100 PRESSURE GAUGE	34
0082418	799003	125 GALLON STRIP	34
0082451	720060	BLOCK-CABLE SQUARE	30
0082491	715132	SELF CENTER TOGGLE SWITCH	28-29
0082521	760034	PUSHER MAC VALVE	16
0082526	730011	2-1/2" RUBBER STRAP	35
0082629	705004	10" CHUTE HOLD DOWN ASSEMBLY	5
0082629	705026	15" CHUTE HOLD DOWN ASSEMBLY	5
0082650	705002	PLASTIC CHUTE HOLD DOWN HANDLE	5
0082652	205018	STRIP-MUD FLAP BOLT	36
0082654	730012	10" RUBBER STRAP	5
0082658	730013	15" RUBBER STRAP	5
0082982	285152	TECH FORCE PUMP CONTROL ARM	30
0082988	750020	HYDRAULIC CONTROL CYLINDER	30
0084007	205017	ANGLE-CENTER BRACE, UNIVERSAL	36
0084325	285088	BRKT-COOLER MOUNT SLUMP GAUGE	31
0084336	730014	FENDER CUSHION END RUBBER	36
0084391	730026	FENDER CUSHION CENTER	36
0084799	215053	PENDANT CORD HOLDER	14
0084817	215185	VALVE MOUNT MAC	15
0085284	760032	CHUTE LOCK MAC VALVE	16
0085288	760033	HOPPER MAC VALVE	16
0085426	705200	2-1/2" THUMB PIN	19
0085427	705201	2" THUMB PIN	19
0085478	730040	CON-TECH MUDFLAP	36
0085693	715130	SELF CENTER TOGGLE SWITCH	29
0085699	760024	0-5000 AXLE PRESSURE GAUGE	31
0085713	760160	CHUTE FLOW CONTROL-UP	22-23
0101291	760004	VALVE-SHUT OFF	34
0101291	760004	VALVE-SHUT OFF	34
0101564	720012	SLEEVE-COMPRESSION	34
0101653	710010	ADAPTER-NPT TO TUBE	34
0102021	730025	HOSE-PUSH LOCK-SPECIFY LENGTH	33
0102021	730025	HOSE-PUSH LOCK-SPECIFY LENGTH	34
0102028	730001	1" WATER HOSE-SPECIFY LENGTH	33
0103384	710008	NIPPLE-PUSH LOCK	34
0103384	710008	NIPPLE-PUSH LOCK	33
0106555	760037	FILTER ASSEMBLY BY-PASS INDICATOR	20-21
0106592	760161	CHECK VALVE (5 PSI)	22-23
0106596	760159	CHUTE FLOW CONTROL-DOWN	22-23
0107596	750001	CYL CHUTE LIFT, DBL ACT W/IFF	19
0107596	750001	CYLINDER-CHUTE LIFT, DOUBLE ACTING W/IFF	19
0107615	750000	CYLINDER CHUTE LIFT, SINGLE ACTING W/IFF	19
0107616	750002	CYLINDER HOPPER AIR LIFT	7
0108105	760015	MTM PARKER VALVE	22-23
0108106	715000	MTM COIL	22-23
0108553	735003	HIGH PRESSURE FILTER ELEMENT	20-21

Part Number Cross Reference

MTM#	CTM#	DESCRIPTION OF PART	PAGE#
0108554	725019	HIGH PRESSURE FILTER O-RING	20-21
0108555	735002	VENTED OIL TANK CAP	32
0108575	740000	HAYDEN FAN COOLER (MTM)	18
0108575	740000	ASSEMBLY-FAN COOLER W/BRACKETS	18
0110147	705511	HANDLE-CONTROL BOX	29
0110194	730200	TOGGLE SWITCH BOOT	28
0110233	765006	REAR CONTROL PENDANT	28
0113100	765091	UP FLOW CONTROL	22-23
0115103	799005	200 GALLON STRIP	34
0115184	705020	SPRING-FLOPPER 1 PIECE	33
0115212	725011	GASKET-FLOPPER	33
0115328	225025	CHUTE-MAIN SAFETY CHAIN	4
0115329	780000	CABLE CONNECTOR LINK	5
0115908	730029	FLOATING BALL	34
0121414	735004	COALESCING FILTER ASSEMBLY	16
0123023	725015	INPUT/OUTPUT SHAFT SEAL KIT-LIP STYLE	20-21
0126551	760095	PILOT OP CHECK VALVE - CHUTE UP/DOWN	22-23
0127504	795006	1350 SERIES PUMP YOKE	20-21
0127504	795005	1350 U-BOLT	20-21
0130256	215080	LIGHT BAR TUBE	7
0130626	215208	SPRAYER LOOP	9
0131433	720000	SPACER, ROLLER	12
0150065	285107	STRAP-FRONT MNT OIL TANK	32
0150314	215182	HOSE HOOK	9
0150350	215094	CHUTE RACK PED MOUNT WLDT	5
0150360	285104	FRONT MOUNT OIL TANK WLDT	32
0150365	285116	FRAME MNT OIL RESERVOIR WLDT	32
0150425	285133	BRACKET-ROLLER	12
0150441	770002	DRUM ROLLER-CASTING	12
0150442	755002	DRUM ROLLER	12
0150443	775002	SHAFT-ROLLER	12
0150488	255033	FIN CAP 3/16"	39
0150766	285021	WATER TANK SIGHT GAUGE MOUNT	34
0150766	285039	TANK CONTROL MOUNT	34
0150824	760031	WATER TANK BLOCK ASSEMBLY	34
0150831	730018	FLOPPER SEAL	33
0150832	770001	FLOPPER TOP CASTING	33
0150926	285145	PUMP CABLE MOUNT SHORT	30
0150978	215092	CHUTE RACK PED MOUNT STOP	5
0151234	215174	PIVOT BRACE B	10-11
0151236	215168	AIR CHUTE LOCK MOUNT A	10-11
0151277	215103	DISC BRAKE PLATE	10-11
0151310	770007	CHUTE LOCK CLAMP ASSEMBLY	10-11
0151315	770005	CHUTE CLAMP BASE	10-11
0151320	770006	CHUTE LOCK CLAMP CAM	10-11
0151486	255099	SURGE BLADE W/TAB	39
0151650 / 1169761	225001	CHUTE-EXTENSION WLDT STEEL	4
0151660 / 1169795	225053	CHUTE-PAVER TRANSITION WLDT	4
1107493	225067	CHUTE-EXTENSION WLDT ALUMINUM	4
0151775	285063	150 GAL WATER TANK WLDT-STEEL	33
0152000	205013	SUPPORT-FRONT, STEEL, RH, WLDT	36
0152001	205014	SUPPORT-FRONT, STEEL, LH, WLDT	36
0152005	205002	SUPPORT-FENDER, REAR, STEEL, RH, WLDT	36
0152006	205003	SUPPORT-FENDER, REAR, STEEL, LH, WLDT	36
0152294	215116	MAIN PIVOT LOWER SEAL RING	9
0152395	215015	UPPER LADDER WLDT	14
0152454	255035	BELLY LINER	39
0152479	255004	HATCH COVER	39
0152479	255004	SURGE BLADE 3 TAB	39
0152480	255002	HATCH FRAME	39

Part Number Cross Reference

MTM#	CTM#	DESCRIPTION OF PART	PAGE#
0152605	215017	LOWER LADDER W/LATCH	14
0152625 / 1145579	225048	CHUTE-MAIN WLDT	4
0152630 / 1145902	225030	CHUTE-FOLD OVER WLDT	4
0152641	770004	CHUTE CLEVIS-CAST	10-11
0152717	205015	BRACE-FENDER, CENTER	36
0152749	205001	BLANK-FENDER, STEEL, 107"	36
0152761	285022	SIGHT GAUGE BRKT	34
0152761	285038	90 GAL SIGHT GAUGE BRACKET	34
0152766	705013	NUT-SITE GLASS	34
0152774	710002	SITE GLASS MOUNT	34
0152930	215085	CHUTE RACK-SIDE MOUNT WLDT	5
0153000	205050	SUPPORT-FRONT, ALUMINUM, RH WLDT	36
0153001	205051	SUPPORT-FRONT, ALUMINUM, LH WLDT	36
0153005	205043	SUPPORT-FENDER, REAR, ALUMINUM, RH, WLDT	36
0153006	205055	SUPPORT-FENDER, REAR, ALUMINUM, LH, WLDT	36
0153203	205019	BLANK-FENDER, ALUMINUM, 107"	36
0153289	215179	LUG HOPPER PIVOT	9
0153295	215128	REAR PIVOT HOUSING A WLDT	10-11
0153325	215046	UPPER PLATFORM BMIII/BMV WLDT	14
0153329	215012	32.66" RAILING UPPER PLATFORM	14
0153330	215055	COLLECTOR STANDARD WLDT	8
0153338	215026	PLATE-RAIL SUPPORT	14
0153525	215163	WATER INJECTION TUBE BOLT ON WLDT	9
0153535	215060	COLLECTOR PAVER WLDT	8
0153574	215159	DRUM DEBOUNCER	9
0153576	215180	HOPPER SUPPORT WIDE LH	9
0153577	215181	HOPPER SUPPORT WIDE RH	9
0153578	215077	CHARGE HOPPER LIGHT BAR	7
0153578	215280	HOPPER LIGHT BRACKET	7
0153605	215289	STANDARD CHARGE HOPPER 4" DROP	7
0153635	215097	REAR PIVOT ASSY 7/8" HARDWARE	10-11
0153648	215173	PIVOT BRACE A	10-11
0153888	705501	CHARGE/DISCHARGE CABLE ARM	30
0153889	705502	THROTTLE CABLE ARM	30
0155000	285112	23" BM OIL RESERVOIR WLDT	32
0160329	215082	33.66" RAILING UPPER PLATFORM WLDT	14
0164386	765095	2200 PSI RELIEF VALVE	20-21
0173331	765096	PILOT OP CHECK VALVE	20-21
0181325	285010	MTM BMIII REAR BUMPER	38
0181341	785000	6" AIR CHUTE LOCK EXT	10-11
0182411	215009	PLATFORM MOUNT	14
0182615	285099	OIL RESERVOIR BRKT W/TAB WLDT	32
0182770	285074	125 GAL WATER TANK WLDT-ALUM	33
0182800	285075	150 GAL WATER TANK WLDT-ALUM	33
0182874	285096	CROSS MOUNT WATER TANK STRAP WLDT	35
0183111	720005	CONE, ROLLER BEARING	12
0183112	720006	ROLLER BEARING CUP	12
0183122	785001	#16 BRAKE CAN	10-11
0186730	765094	COIL SPACER	22-23
0189001	285013	MTM BMV REAR BUMPER FRAME MOUNT	38
0189065	720014	MTM BMV CYLINDER BUSHING	24-25
0189069	775010	AXLE CYLINDER PIVOT PIN 6-5/8"	24-25
0198680	765092	CARTRIDGE ONLY-RAISE/LOWER	22-23
0214652	799040	REAR CONTROL PENDANT PLACARD	28
0215208	725006	2 PC SQUARE HATCH COVER	39
0215217	730005	2" RUBBER STRAP	35
0215252	725014	SEAL-SWIVEL BEARING	10-11
0215258	725012	SEAL, FELT	12
0215805	780060	44BB60 CONTROL CABLE	30
0215807	780084	44BB84 CONTROL CABLE	30

Part Number Cross Reference

MTM#	CTM#	DESCRIPTION OF PART	PAGE#
0215808	780096	44BB96 CONTROL CABLE	30
0215812	780144	44B144 CONTROL CABLE	30
0215816	780192	44BB192 CONTROL CABLE	30
0215818	780216	44BB216 CONTROL CABLE	30
0215821	780252	44BB252 CONTROL CABLE	30
0215822	780264	44BB264 CONTROL CABLE	30
0215823	780276	44BB276 CONTROL CABLE	30
0215824	780288	44BB288 CONTROL CABLE	30
0215825	780300	44BB300 CONTROL CABLE	30
0215830	780360	44BB360 CONTROL CABLE	30
0215833	780051	44BP396 THROTTLE CABLE	30
0215833	780396	44BB396 CONTROL CABLE	30
0500407	285124	BRKT-FRONT, TRANS, T-SLUMP MNT	31
0500435	215050	PENDANT HOLDER WLDT W/WRAP	24
0500485	285091	CROSS MOUNT WATER TANK BRKT WLDT	35
0500562	285090	BRKT-OIL FILTER MOUNTING	32
1105498	215346	PAVER CHARGE HOPPER 4" DROP	7
1105770	215001	GUARD MIXER, NON PAVER	9
1106794	215002	GUARD-MIXER	9
1138195	730060	TYPE III BIB W/O SLITS	8
0115236	730002	TYPE III BIB	8
0082651	730041	MUDFLAP - 24" X 24"	36
0107530	750013	RB MTM BMIII CYLINDER 2"	19
0107559	750012	RB MTM BMIII CYLINDER 2-1/4"	19
0189976	750011	RB MTM BMV CYLINDER	19
1186060	760002	GAUGE, SLUMP METER 0-5000	31
1168364	730028	6' SITE GLASS	34
1168394	760027	AXLE PRESSURE ADJUSTING VALVE	22-23
1168396	760028	MTM CARTRIDGE & COIL	22-23
1169028	285032	WATER TANK MOUNT STRAP WLDT	35
0084296	285123	BRKT-REAR PED, T-SLUMP MNT	31
1169354	780001	CHUTE RACK CABLE 30"	5-6
1169355	780002	CHUTE RACK CABLE 38.5"	5-6
1169356	780003	CHUTE RACK CABLE 47.5"	5-6
0115330	780004	CHUTE RACK CABLE 49"	5-6
1147504	205081	BLANK-FENDER, ALUMINUM, 70" RH	36
1147505	205061	BLANK-FENDER, STEEL, 70" RH	36
1147503	205060	BLANK-FENDER, STEEL, 70" LH	36
1147514	205082	BLANK-FENDER, ALUMINUM, 70" LH	36
0116059	205016	STRAP-CENTER	36
0153306	215178	MOUNT HOPPER CYLINDER	9
0153373	215076	CHARGE HOPPER CYL LUG	9
0117086	790011	AXLE KING PIN KIT	24-25
1148251	285015	MTM BMV REAR BUMPER	38



CREDIT APPLICATION FOR A BUSINESS ACCOUNT

BUSINESS CONTACT INFORMATION

Date Business Commenced: ____ / ____ / ____

Name: _____ Title: _____

Company Name: _____

Registered Address: _____

Sole Proprietorship: _____ Partnership: _____ Corporation: _____ City State Zip
Other: _____

BUSINESS AND CREDIT INFORMATION

Primary Address: _____

How Long at Current Address? _____ City State Zip
E-mail: _____

Telephone: (____) _____ Fax: (____) _____

Bank Name: _____

Bank Address: _____

Type of Account: _____ City State Zip
Account No.: _____

BUSINESS/TRADE REFERENCES

Company Name: _____

Address: _____

Telephone: (____) _____ City State Zip
Fax: (____) _____

E-mail: _____ Type of Account: _____

Company Name: _____

Address: _____

Telephone: (____) _____ City State Zip
Fax: (____) _____

E-mail: _____ Type of Account: _____

Company Name: _____

Address: _____

Telephone: (____) _____ City State Zip
Fax: (____) _____

E-mail: _____ Type of Account: _____

All invoices are to be paid 30 days from the date of invoice. Claims arising from invoices must be made within seven working days.

By submitting this application, you authorize Con-Tech Manufacturing, Inc. to make inquiries into the banking and business/trade reference that you have supplied.

Signed: _____ Title: _____ Date: _____

PLEASE FAX CREDIT APPLICATION TO: 507-374-2548

UPGRADE to SUPERFORMANCE HIGH PERFORMANCE

Completely redesigned head fabricated with A.R. steel

More Wear Resistant
Up to 300% more wear resistant than typical Gr. 50 spun heads.

Thicker
1/4" and 5/16" heads are true nominal thickness unlike spun heads that get thin on the radius.

Lighter
1/4" heads are 172lbs lighter than 1/4" spun heads.
5/16" heads are 101lbs lighter than 1/4" spun heads.

High capacity head and belly sections allow for more material in the mixing bowl.

Straight cone taper allows for a smooth discharge with virtually no surging, while allowing maximum discharge performance.



NEW Ball Buster paddle system is strategically located for breaking apart floating dry balls.



Solid roller track is lighter and stronger than hollow designs, Providing 350% more contact surface area and eliminates flexing and cracking.



New fin spiral design, with self cleaning fins



507-374-2239

www.ctmmixers.com

Con-Tech

MANUFACTURING, INC.

Con-Tech Headquarters
67079 170th Avenue
Dodge Center, MN 55927
507-374-2239 ph
507-374-2548 fax

Texas Branch (Dallas)
4906 Dillehay Drive, Suite 300
Allen, TX 75002
972-941-8592 ph
972-941-8911 fax

Georgia Branch (Atlanta)
104 Hudson Industrial Drive
Griffin, GA 30224
770-227-2001 ph
770-227-3021 fax

Arizona Branch (Phoenix)
4855 West McDowell Road
Phoenix, AZ 85035
507-206-7276 ph
507-374-2548 fax



25%
LARGER
MIXING
BOWL

The **HIGH PERFORMANCE DRUM** is designed from head to tail to meet and exceed the demands of producers everywhere.

From **EXTREME** paving, down to filling wheel barrows, the all new

Con-Tech HP drum is the **ULTIMATE SOLUTION!**

Once again, you asked, and **Con-Tech** listened.



Ph: (507) 374-2239 Fax: (507) 374-2548
www.ctmmixers.com

